

KENTUCKY RE-ENTRY PROBE EXPERIMENT – 2 (KREPE-2)

Technical Description

The Kentucky Re-Entry Probe Experiment -2 (KREPE-2) is a non-orbital research project developed by the University of Kentucky. The project is supported by various NASA centers. The goals for the mission payload are to: 1) provide an affordable technology testbed for atmospheric re-entry experiments; and 2) collect material response data for Thermal Protection Systems in order to allow validation of computational models.

The concept of operations is shown graphically in Figure 1.

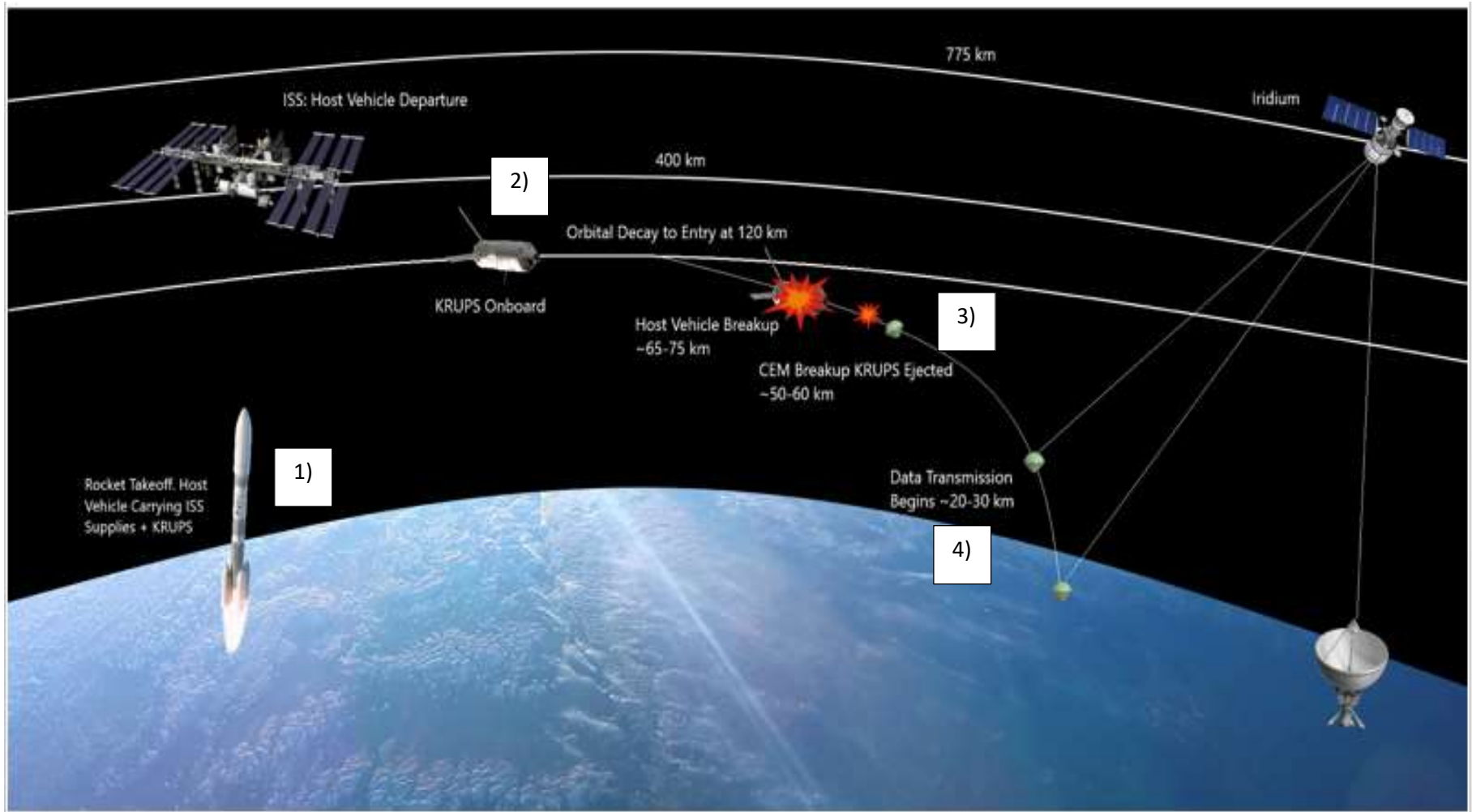

Figure 1. KREPE-2 Concept of Operations: 1) KREPE-2 capsules transported to International Space Station via supply vehicle. 2) De-orbited with KREPE-2 capsules onboard the transport vehicle. 3) Capsules emerge upon vehicle breakup during re-entry. 4) KREPE-2 sensor data transmitted via Iridium satellite network.

KREPE-2 is a self-contained payload, consisting of five KRUPS capsules (Kentucky Re-entry Universal Payload System) with identical electronics. Each KREPE-2 capsule contains batteries, an Iridium modem, antenna, embedded controller, sensors, and associated wiring. Figure 2 shows details of the size and make up of a capsule. Details on the modem and transceiver are in the *Iridium Modem and Antenna Information* document.

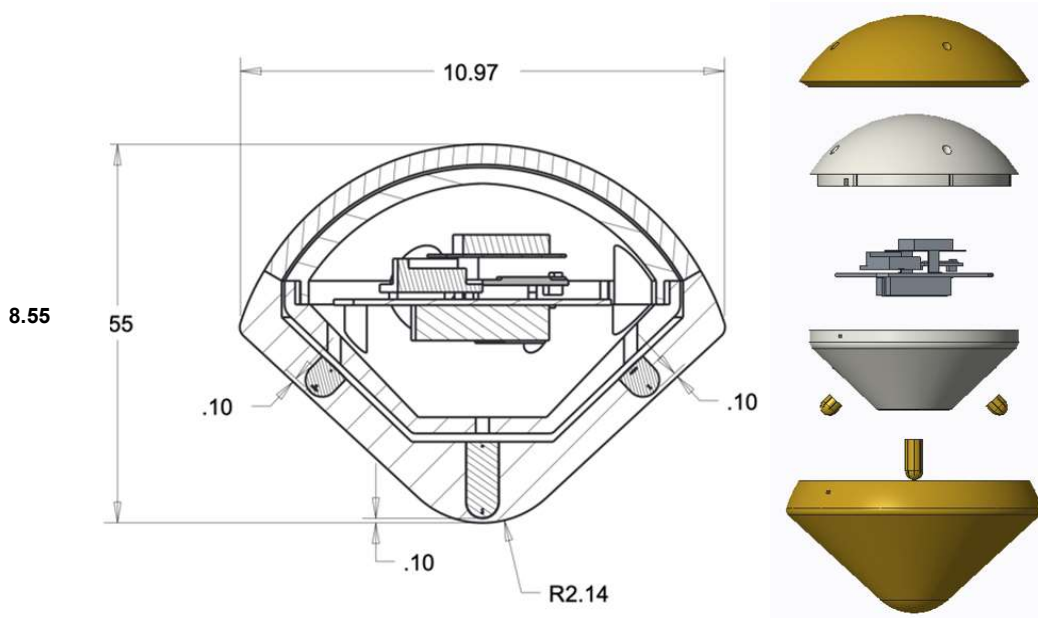

Figure 2. KREPE-2 Capsule Showing Internal Structural Housing with the Thermal Protection System (TPS) attached (gold color parts). The units are inches.

The capsules will be transported to the International Space Station (ISS) via a visiting vehicle. While in transport, KREPE-2 will be housed in an RF-shielded housing. Figure 3 shows a capsule inside the KREPE-2 RF shield and housing, known at the KREM.

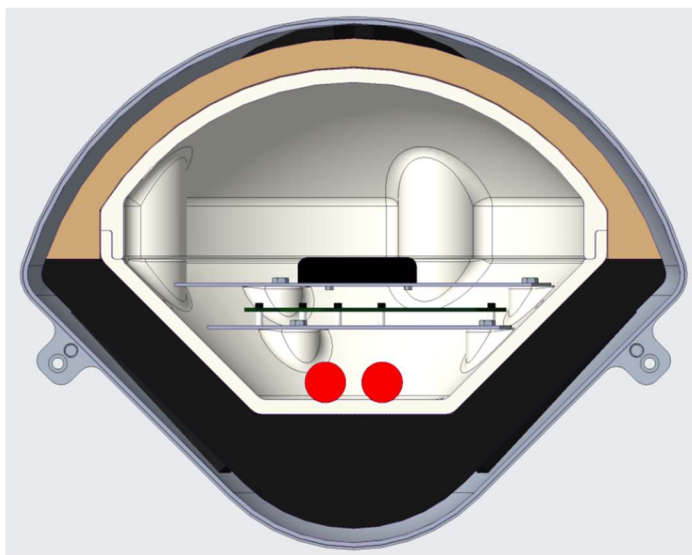

Figure 3. KREPE-2 full configuration showing KRUPS capsule installed in KREM housing.

The KREPE-2 capsules require no communications while in transport to the ISS and will be stowed without connection to power. The capsules will remain in the unpowered state while on the ISS. Prior to departing the ISS, the astronaut crew will install the capsules into the return vehicle. At that time, the crew will activate the capsules, enabling power to their embedded controllers. The controllers will begin monitoring sensors but power is inhibited to the Iridium modems, preventing accidental RF transmissions. Further details of the controller and other safeguards against unwanted transmissions are found in Appendix A.

The return vehicle will then be released from the ISS and de-orbited. The KREPE-2 capsules are designed to survive the return vehicle break up as it re-enters the atmosphere. The KREPE-2 embedded control system is designed such that data transmission to the Iridium satellite network will not occur until after breakup of the return vehicle. The breakup event is detected using onboard capsule sensors. The capsules will be ejected from the visiting vehicle and the KREM RF shield will be released. Once the KREM is released, power will be applied to the modem and the KREPE-2 capsules will begin transmission through the Iridium satellite network to retrieve sensor material response data for the thermal protection system. The transmissions will continue through the remainder of the descent until splashdown or until the batteries are drained, if the capsules survive the ocean landing (a matter of a few minutes).

APPENDIX A: KREPE-2 Flight Computer and RF Safeguards

KREPE-2 FLIGHT COMPUTER

Figure A-1 shows a block diagram of the KREPE-2 flight computer.

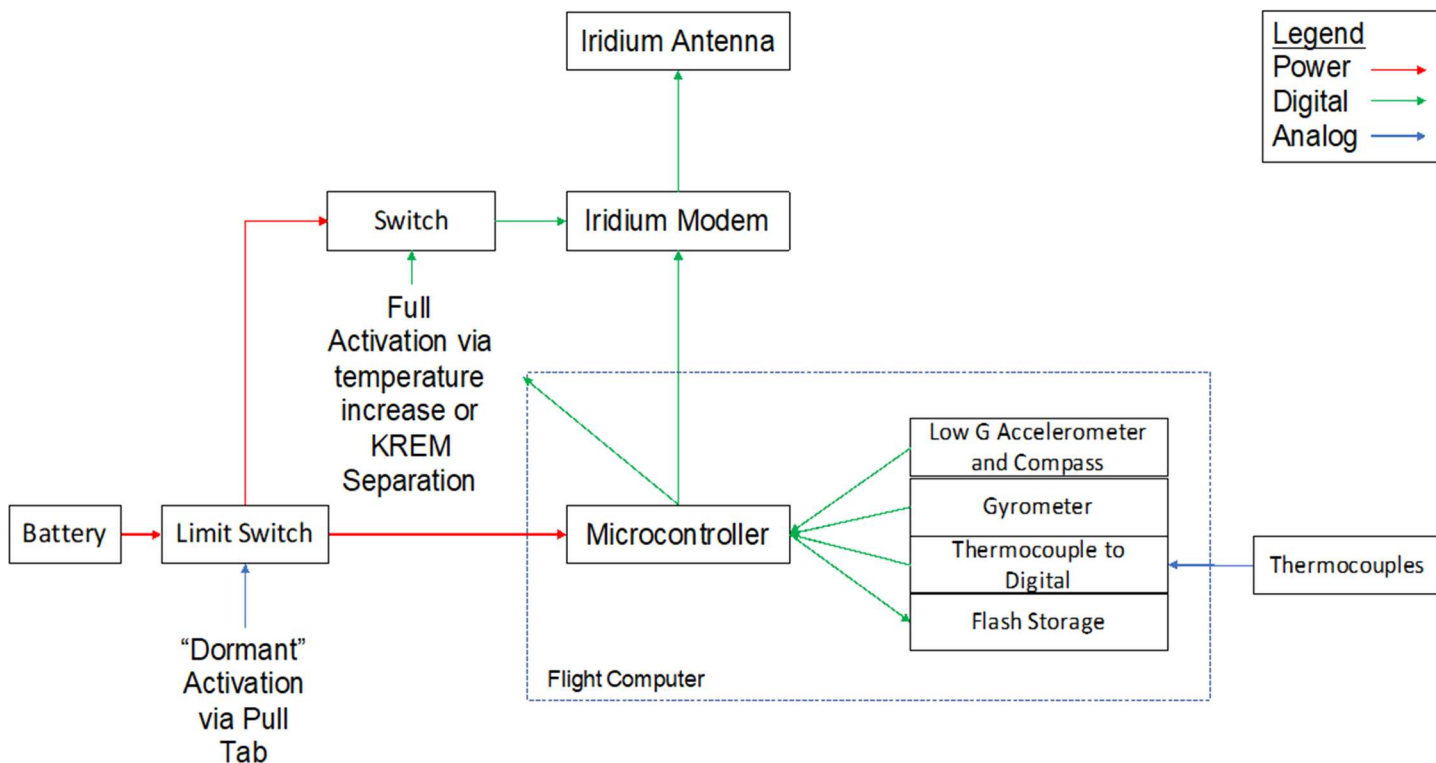

Figure A-1. KREPE-2 flight computer block diagram

After loading capsules into the return vehicle, the ISS crew will pull a tab to enable power to the flight computer (ARM microcontroller). Once the tab is pulled, the flight computer is powered on and software initiation places it in a stand-by mode. In the stand-by mode, the microcontroller only monitors sensors that will be used later for activation when the return vehicle has departed the ISS.

The "Switch" (solid-state relay) is controlled by an output of the microcontroller. The switch is initially in the open state and battery power for the Iridium radio is disabled, preventing any RF transmission. The open switch is the first inhibit to any inadvertent transmission of the Iridium modem. The KREM Faraday cage is still in place and provides a second inhibit to prevent accidental transmission (per NASA safety requirements). The KREPE-2 capsules will remain in this stand-by, shielded state until the return vehicle has departed the ISS, de-orbited, and re-entry breakup has occurred.

The KREPE-2 capsules are designed to survive the return vehicle breakup as it re-enters the atmosphere. Upon breakup, the capsules will be ejected from the visiting vehicle debris field and the KREM RF shield will be released when the plastic bolts holding the shield melt. Upon release of the shield, the KREPE-2 capsules will then enter an active state.

KREPE-2 capsule activation involves detection of two events: a significant increase in temperature and release of the KREM RF shield. Thermal sensors provide the microcontroller with data to sense the heating event. An electrical continuity check provides the microcontroller with data to indicate the KREM RF shield has been released. The flight controller now puts the capsules in their active state. In the active state, the KREPE-2 systems begin initialization, including applying power to the Iridium modem. At that time, the capsules will begin transmitting data, via the Iridium satellite network, from the various KREPE-2 sensors until splashdown. The descent only lasts for a few minutes. Should the KREPE-2 capsules survive splashdown, and if they do not sink, they will continue to send transmissions until the modest battery capacity is emptied (a matter of a few more minutes).

KREPE-2 RF SAFEGUARDS TO PREVENT UNINTENDED TRANSMISSIONS

INITIAL UNPOWERED STATE

The KREPE-2 capsules are transported to the ISS in an unpowered state. A pull-tab power interrupt prevents the battery from energizing any of the electronics. This eliminates the possibility of any RF transmissions for the majority of the mission.

KREM RF SHIELD

Once the KREPE-2 capsules are stowed in the return vehicle, the pull-tab power interrupt is removed by an astronaut and the electronics are placed in a stand-by mode. Under normal operation, software inhibits prevent powering up the Iridium modem by disabling a switch between the battery and the Iridium modem (see Fig. A-1). Were there some type of unanticipated anomaly causing the modem to transmit, the KREM RF shield, acting as a Faraday cage, will contain the RF emissions. Note that the KREM cage is also NASA-required safety inhibit to prevent interference with ISS command and control.

The KREM RF shield is maintained in place until the return vehicle departs the ISS, de-orbits, and the capsules are released into the atmosphere after the vehicle break-up. At that time, the shield will be released and power will be applied to the Iridium modem. The KREM RF shield, thus, prevents any RF transmissions for the majority the mission. After shield release, RF transmissions during descent would last no longer than a few minutes before splashdown.

KREPE-2 CONTROLLER - POWER ANOMALY PROTECTION

RF transmission is possible during descent, once the KREM RF shields are released from the KREPE-2 capsules. Each of the KREPE-2 capsules uses a Teensy 3.5 microcontroller. The Teensy controller powers up into a known safe reset state. No outputs occur until the processing state is initiated (see Fig. A-2).

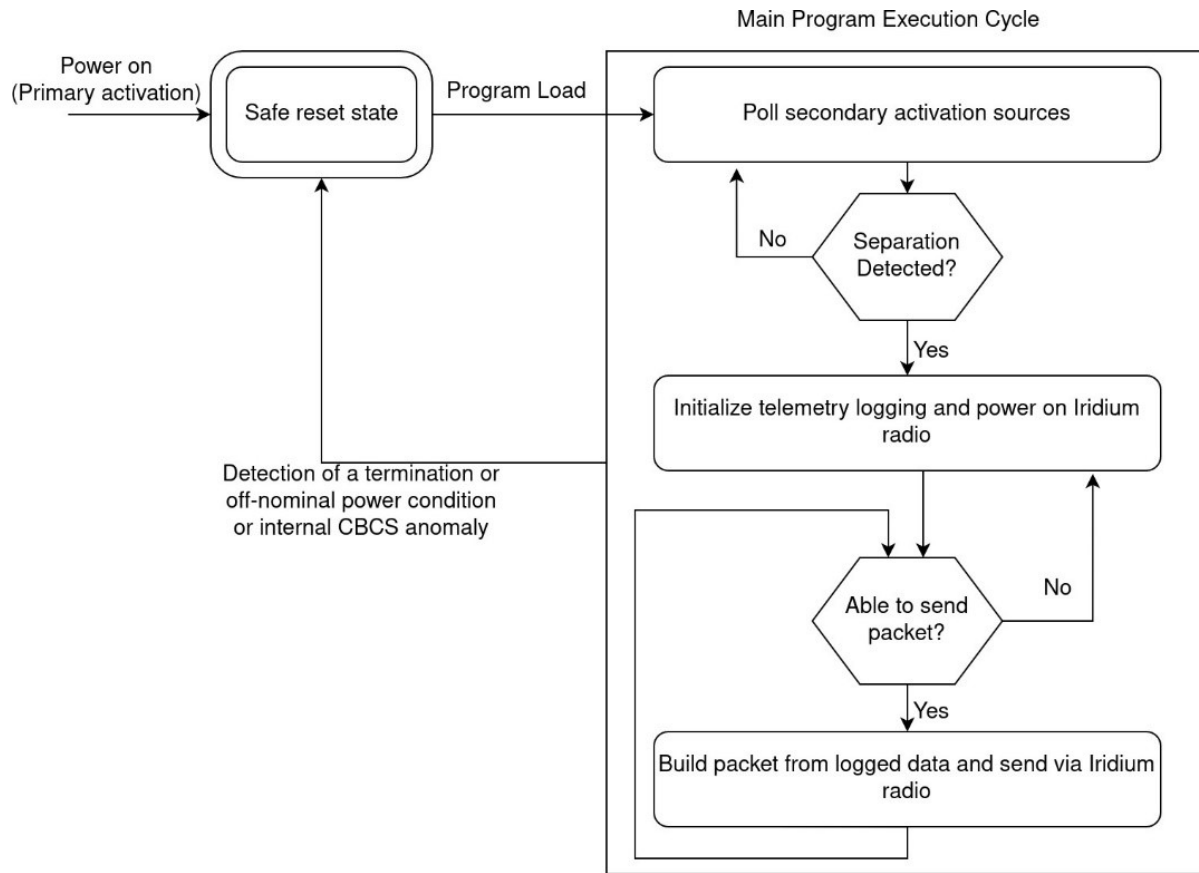

Figure A-2. Overview of main execution cycle showing return to safe high impedance reset state upon startup and abnormal power condition.

Upon both power up (after primary activation via pull-tab) and detection of an off-nominal power condition, the Teensy microcontroller will enter a safe reset state, where all GPIO pins controlling critical system functions are set to a high impedance value. This high impedance state removes power to the Iridium radio by opening the switch from the battery (see Fig. A-1), preventing Iridium transmission due to a possible off-nominal power malfunction.

KREPE-2 CONTROLLER – SOFTWARE ANOMALY PROTECTION

During descent, after release of the KREM RF shield, a programmed “watchdog timer” will monitor the software program to ensure that the software process is progressing as designed. In the event a timer-anomaly is detected, the Teensy microcontroller will enter the safe reset state, setting all GPIO pins to the high impedance value. This high impedance state removes power to the Iridium modem by opening the switch from the battery (see Fig. A-1), preventing Iridium transmission due a software anomaly.

KREPE-2 CONTROLLER – IRIDIUM MODEM TRANSMITTER CONTROL

During descent, after release of the KREM RF shield, for an Iridium data transmission to occur, two things have to happen. First, the command to the switch (see Fig. A-1) connecting the battery to the Iridium modem through the switch has to be given. At that time, the modem enters a stand-by, non-transmitting state. The second thing that has to happen is the Teensy microcontroller forms a data packet and gives the command for the Iridium modem to transmit. When transmitting, the Iridium modem outputs a “transmit-active” command, which is read by the microcontroller. This command is monitored throughout the software program. In the event transmission is detected outside of normal operating conditions, the Teensy microcontroller will enter the safe reset state, setting all GPIO pins to the high impedance value. This high impedance state removes power to the Iridium modem by opening the switch from the battery (see Fig. A-1), preventing Iridium transmissions due to some other unforeseen anomaly.

KREPE-2 BATTERY CAPACITY LIMIT

The KREPE-2 capsules are relatively small, about 11 inches in diameter. Thus, the battery has limited energy capacity. The descent time to splashdown only lasts a few minutes. In the event a capsule survives splashdown and does not sink, RF transmissions could continue until the battery is sufficiently drained. The modest battery capacity would be the ultimate time limit for any RF transmissions, should all other inhibits fail. If the capsules do not survive splashdown operating normally or sink, then the time window for RF transmissions is that of just the descent, on the order of a few minutes.