

# FPA14-1.6R/1252

## Directional Antenna

### Key Features:

Designed for Inmarsat Satellite Network

Low profile and lightweight design

Suitable for mobile applications

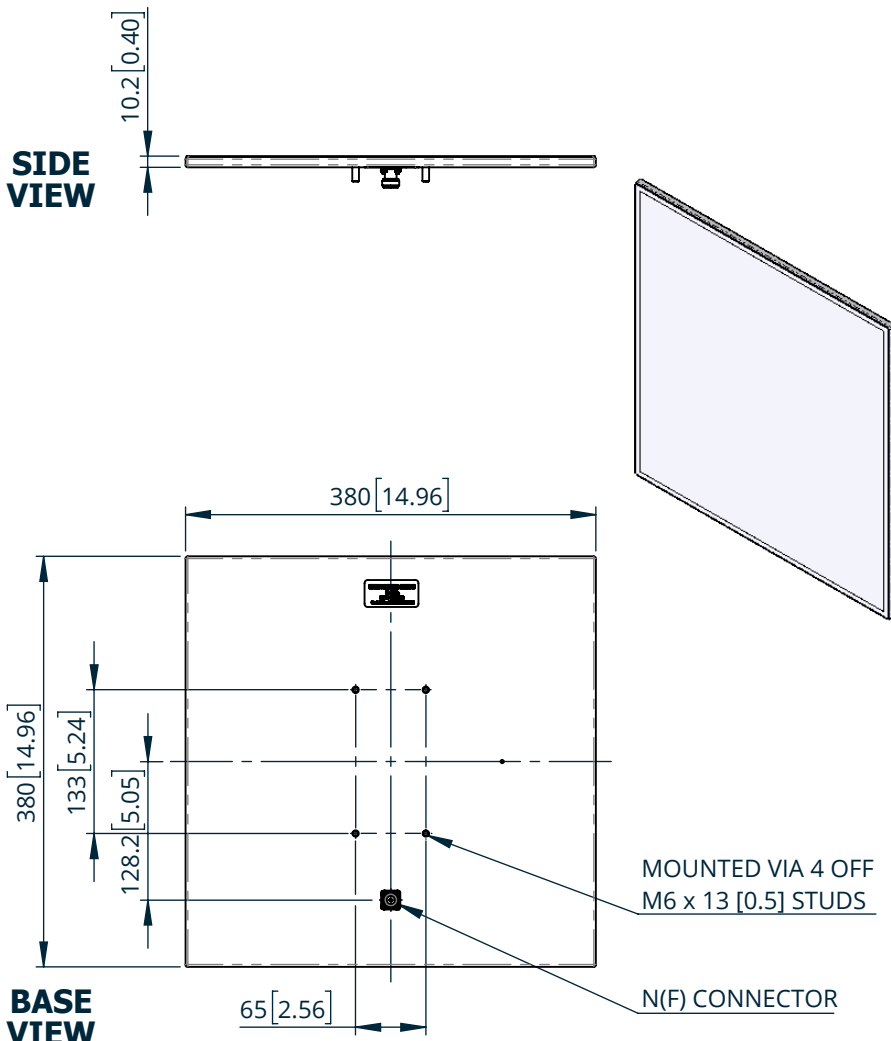
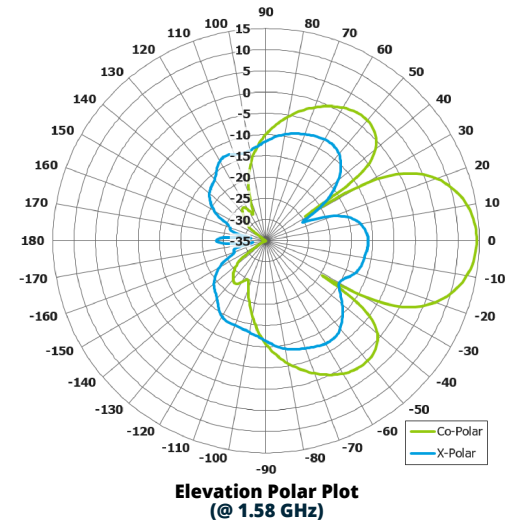
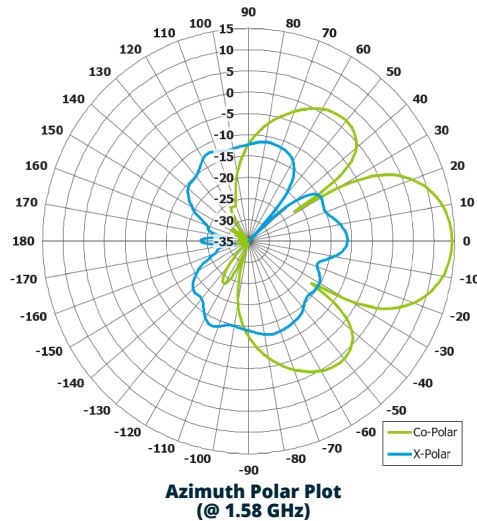

### ELECTRICAL

**Frequency:** 1.5250 to 1.6605 GHz

**Gain:** 14.5 dBiC Typ.

**Polarisation:** Right hand circular

**Beamwidth:** 27° x 27° Typ.

**Axial Ratio:** <1 dB Typ.

**VSWR:** 1.5:1 Max.

**Power Rating:** 10 W

### MECHANICAL

**Standard Finish:** White

**Mass:** 1.0 Kg / 2.2 lbs

**Temperature:** -40 to +60°C

**Wind Loading:** 212 N @ 100 mph

### MOUNTING OPTIONS

**Kits Available:** 056A, 058A & 066A

See separate datasheets

Full radiation patterns and CAD available on request

**DS:** 1252-4

**Issued:** 250521

Dimensions: mm [inches]

# EyeStar-S4 Satellite Transceiver

**Half-Duplex Space Based Communication System  
with Live, Global Coverage**



## Description

The EyeStar-S4 is a half-duplex transceiver radio with ground segment, intended for space use. This small form factor radio provides a live link to the spacecraft, with 24/7 connectivity and global coverage at only 5 s latency. An upgrade to the reliable NearSpace Launch EyeStar-S3, the S4 now includes uplink command capability through communicating with the established Iridium network. More than just a radio, the EyeStar-S4 is a full communication system, including the satellite radio, access to the Iridium network and ground station, NSL servers, and online live data terminal.

## Key Features

- Command and Data Handling TRX Radio communicates Space-to-Space with Iridium Constellation
- 24/7 Global Coverage, livestreaming data directly to Online Console
- Simplex Downlink and Uplink capability with 5 s latency
- Includes full ground segment, using Iridium ground station, NSL servers, and Online Console
- 100% Mission Success for all EyeStar Radios (180+)



Figure 1 EyeStar-S4 Transceiver Radio

## Performance

- 18-202\* byte packet every 15 seconds, up to 1 Mbyte/day
- Excellent polar coverage, no significant dropout zones in orbit
- 100% guaranteed data throughput with handshaking enabled
- Latency of 5 s from S/C to Console
- Successfully communicated with up to 10 RPM tumble
- L-band frequency use

\*Larger packet size not yet tested in orbit

## Reliability

- TRL 9
- Orbit tested up to 600 km
- Autonomous Health and Safety transmissions
- High Reliability mil-spec parts
- EyeStar-S2/S3/S4 heritage of over 180 successfully deployed in orbit
- Certifications/Qualifications

## Basic Specs

SWaP	Spec	Units
Size	60x30x21	mm
Weight	29	g
TX Power	1.0	W
Idle Power	0.25	W
RF Power	1.4	W
Data Rate	<13.5	Bytes/s
Frequency	1622	MHz
Temperature	-30 to +60	°C
Input	6 – 36	V

- FCC Compliant, RE02, Vibe 14.1 GRms, Part 15
- Functional Testing
  - Burn in, Day-in-the-Life
- Environmental Testing
  - Vibe, Thermal, Vac, Bakeout

**Data**

- Ports
  - Serial: Simple TTL Serial Interface
  - Power + Analog Inputs: Up to 6 Analog and 4 Digital Inputs
- Data API accessible

**Additional Features**

- Small form factor patch antenna
- Interfaces directly with NSL GPS

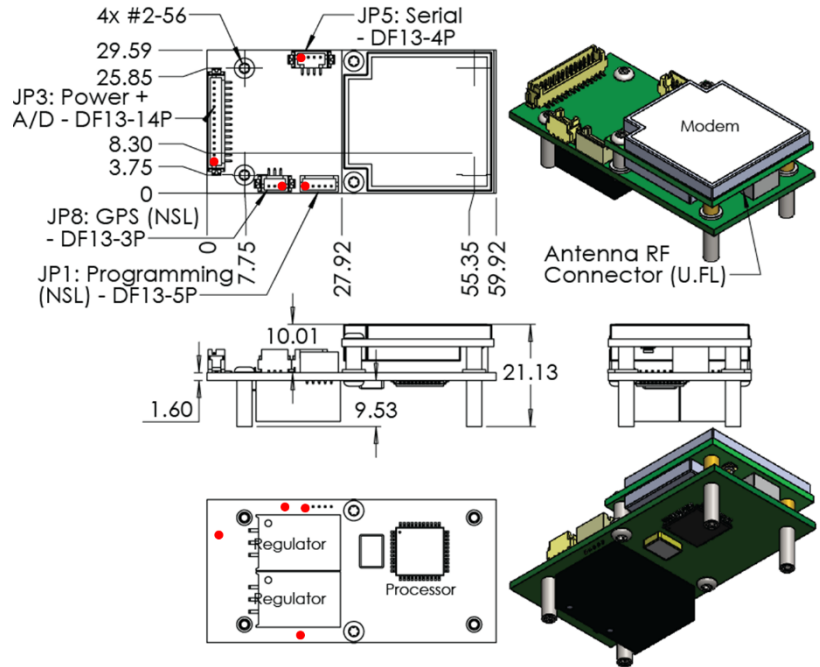

Figure 2 EyeStar-S4 Mechanical Drawing with connectors.

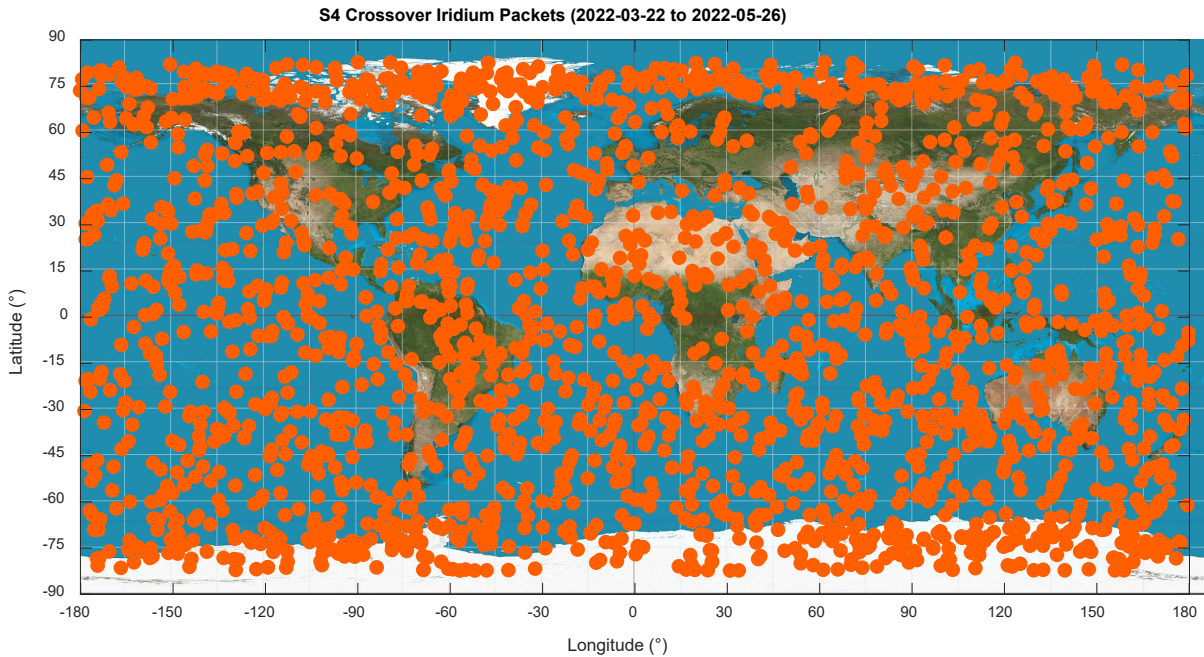

Figure 3 EyeStar-S4 on-orbit data showing the connectivity coverage. Note good polar coverage and no drop out zones.

NearSpace Launch, Inc.  
 79 E Railroad St.  
 Upland, IN, 46989, USA  
[www.nearspacelaunch.com](http://www.nearspacelaunch.com)  
 +1-765-998-8942





# TAOGLAS®



# Datasheet

**Part No:**  
WDMP.2458.A

**Description:**

5dBi Embedded Dual-Band Wi-Fi Circular Polarized 50\*50mm Patch Antenna  
SMA(F) Straight Connector

**Features:**

High efficiency Wi-Fi Patch Antenna including Wi-Fi 6 bands  
Covers Wi-Fi at bands 2.4GHz/5.8/7.1GHz  
Right Hand Circularly Polarized (RHCP)  
Military grade dielectrics & low loss substrates  
High Gain, greater than 5dBi  
Dimensions (with connector): 50 x 50 x 16.57 mm  
Dimensions (without connector): 50 x 50 x 7.07 mm  
Screw mount with SMA(F) Straight connector  
RoHS & Reach Compliant

1. Introduction	3
2. Specifications	5
3. Antenna Characteristics	6
4. Radiation Patterns	9
5. Mechanical Drawing	11
6. Installation Instructions	12
7. Packaging	14
<hr/>	
Changelog	15

Taoglas makes no warranties based on the accuracy or completeness of the contents of this document and reserves the right to make changes to specifications and product descriptions at any time without notice. Taoglas reserves all rights to this document and the information contained herein. Reproduction, use or disclosure to third parties without express permission is strictly prohibited.



# 1. Introduction



The WDMP.2458.A antenna with SMA(F) connector is a circularly polarized Wi-Fi antenna also covering the 7.1GHz Wi-Fi 6 band which consists of an advanced composite dielectric structure, providing better performance at greater distance and a broader band frequency range in the smallest package in the market.

Using military grade substrates, the WDMP.2458.A is aimed at unmanned systems, such as unmanned aerial/ground vehicles (UAVs/UGVs), robotics, and ground controllers/stations, applicable in different sectors from civilian, law enforcement, to defence.

Taking advantage of substrates of low dielectric constant and low dissipation factor, the WDMP.2458.A uses glass microfiber reinforced PTFE substrates to minimize signal transmission loss in order to achieve high efficiency. It performs with high gain of at least over 5dBi at Wi-Fi bands from 2400~2500MHz, 5150~5850MHz and 5925~7125MHz. Using circular polarized signals means the link is more stable for devices where the direction of orientation is unknown or where multipath is an issue.

The WDMP.2458.A's low profile design, equipped with a SMA(F) connector, is easy to install inside a housing or directly onto a PCB mainboard. It has four thru-holes at the patch corners, allowing users to fix the antenna with screws. The antenna has passed ISO 16750 high/low-temperature test and random vibration reliability testing.

Many module manufacturers specify peak gain limits for any antennas that are to be connected to that module. Those peak gain limits are based on free-space conditions. In practice, the peak gain of an antenna tested in free space can degrade by at least 1 or 2dBi when put inside a device. So ideally you should go for a slightly higher peak gain antenna than mentioned on the module specification to compensate for this effect, giving you better performance.

Upon testing of any of our antennas with your device and a selection of appropriate layout, integration technique, or cable, Taoglas can make sure any of our antennas' peak gain will be below the peak gain limits. Taoglas can then issue a specification and/or report for the selected antenna in your device that will clearly show it complying with the peak gain limits, so you can be assured you are meeting regulatory requirements for that module.

For example, a module manufacturer may state that the antenna must have less than 2dBi peak gain, but you don't need to select an embedded antenna that has a peak gain of less than 2dBi in free space. This will give you a less optimized solution. In that case it will be better to go for a slightly higher free space peak gain of 3dBi or more if available. Once that antenna gets integrated into your device, performance will degrade below this 2dBi peak gain due to the effects of GND plane, surrounding components, and device housing. If you want to be absolutely sure, contact Taoglas and we will test. Choosing a Taoglas antenna with a higher peak gain than what is specified by the module manufacturer and enlisting our help will ensure you are getting the best performance possible without exceeding the peak gain limits.

The connector can be customized subject to MOQ, for more information please contact your regional Taoglas customer support team.



## 2. Specifications

Wi-Fi Electrical									
Band	Frequency (MHz)	Efficiency (%)	Average Gain (dB)	Peak Gain (dBi)	Axial Ratio (dB)	Impedance	Max Power Input	Polarization	Radiation Pattern
2.4GHz Wi-Fi	2400~2500	73	-1.3	4.9	< 2	50Ω	10W	RHCP	Omnidirectional
5.8GHz Wi-Fi	5150~5850	80	-0.9	6.3	< 8				
7.1GHz Wi-Fi 6	5925~7125	62	-1.8	5.8	< 10				
Mechanical									
Dimension (mm)	50 x 50 x 7.07 (without connector) 50 x 50 x 16.57 (with connector)								
Antenna Patch Material	PTFE composites								
Connector	SMA(F) Straight								
Weight (g)	32.5								
Environmental									
Temperature Range	-40°C to 85°C								



### 3. Antenna Characteristics

#### 3.1 Return Loss

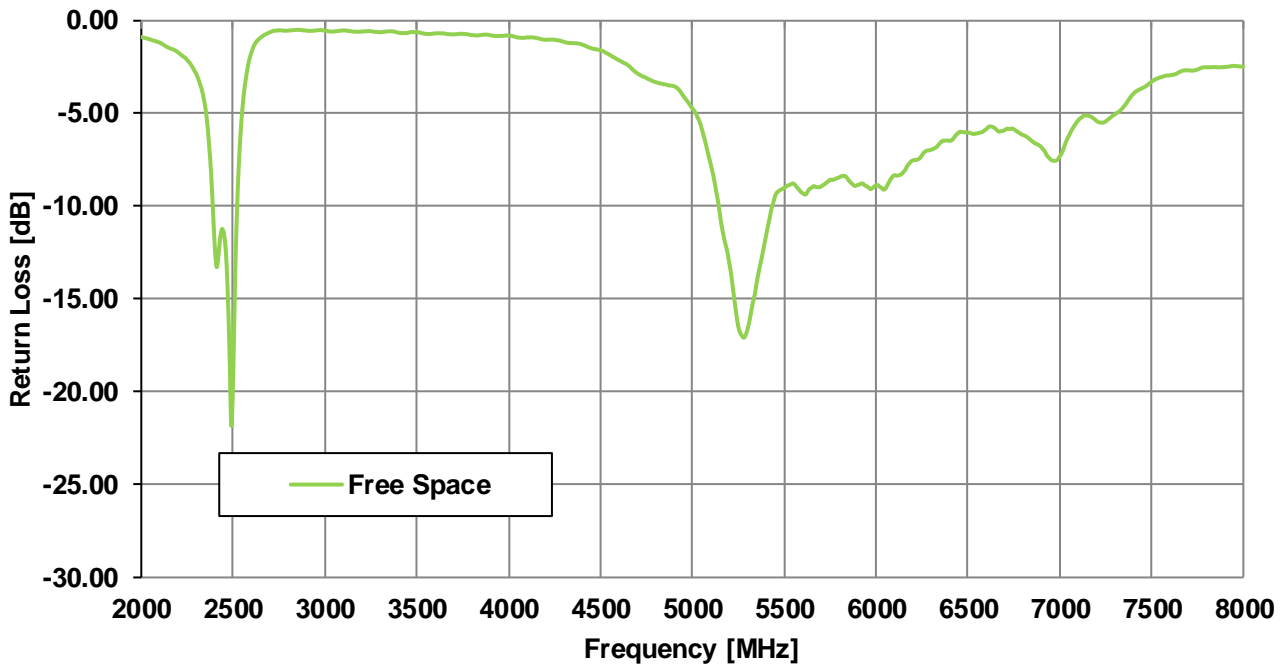

#### 3.2 VSWR

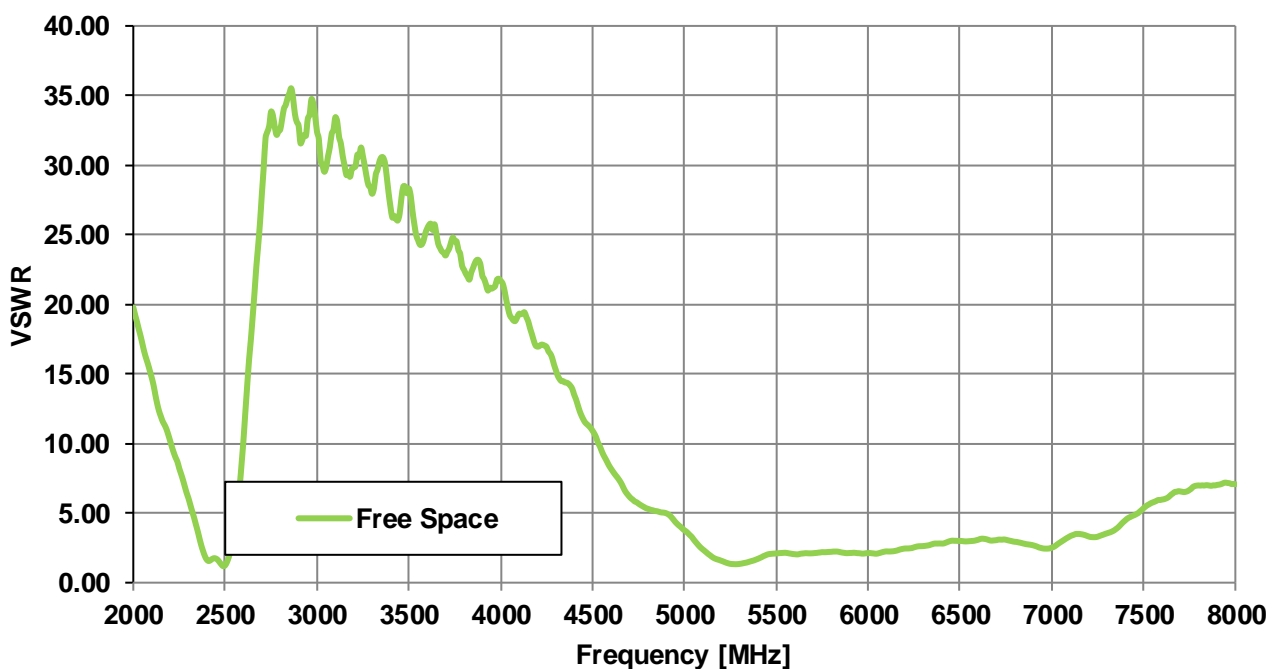

### 3.3 Efficiency

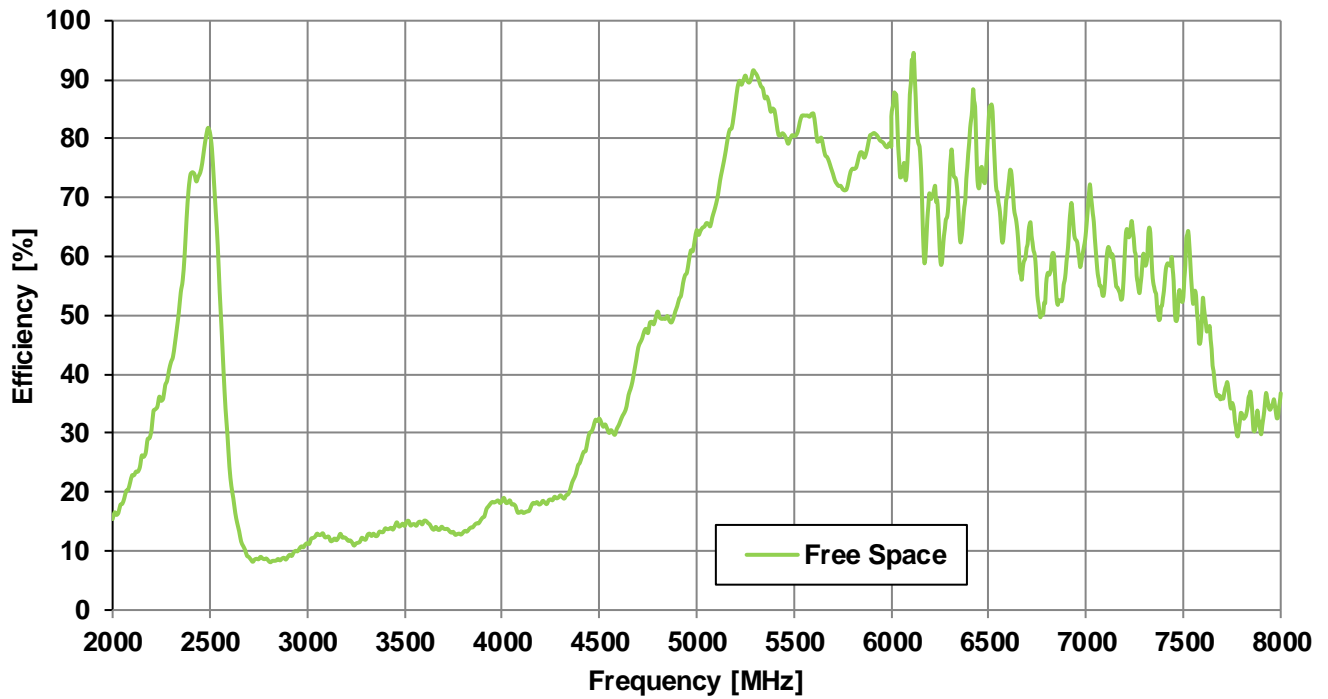

### 3.4 Peak Gain

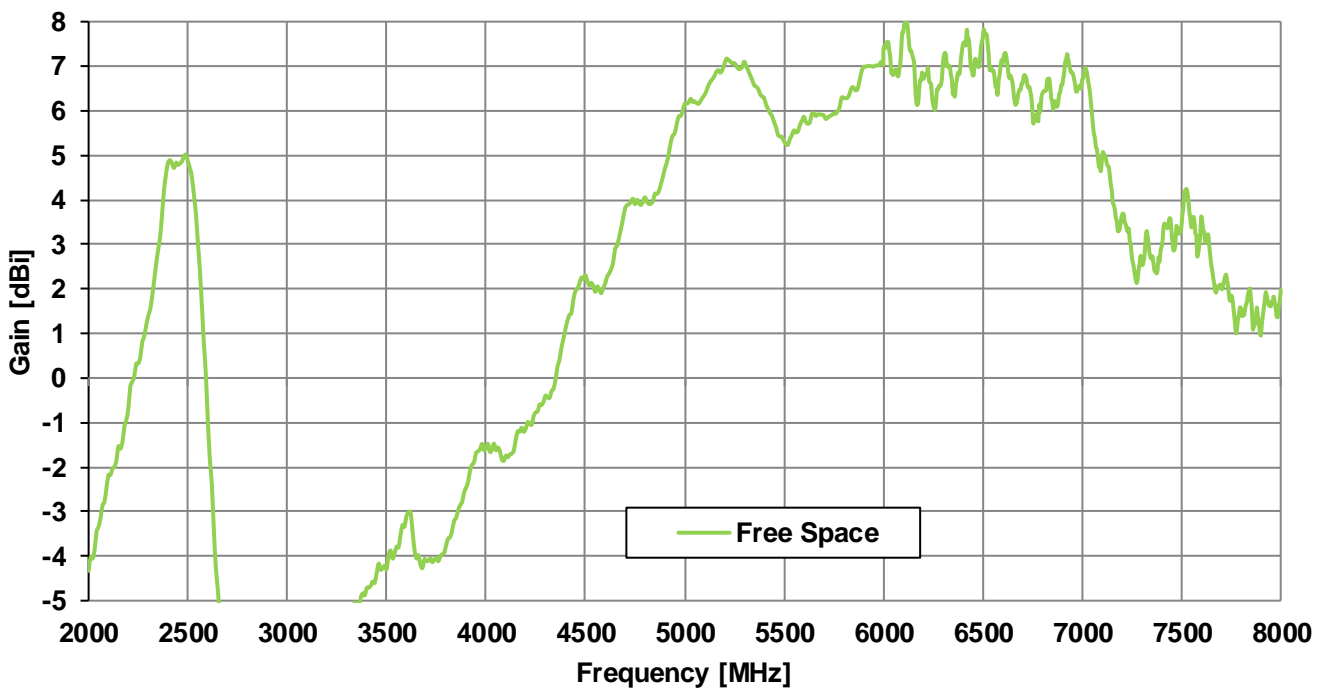

### 3.5 Average Gain

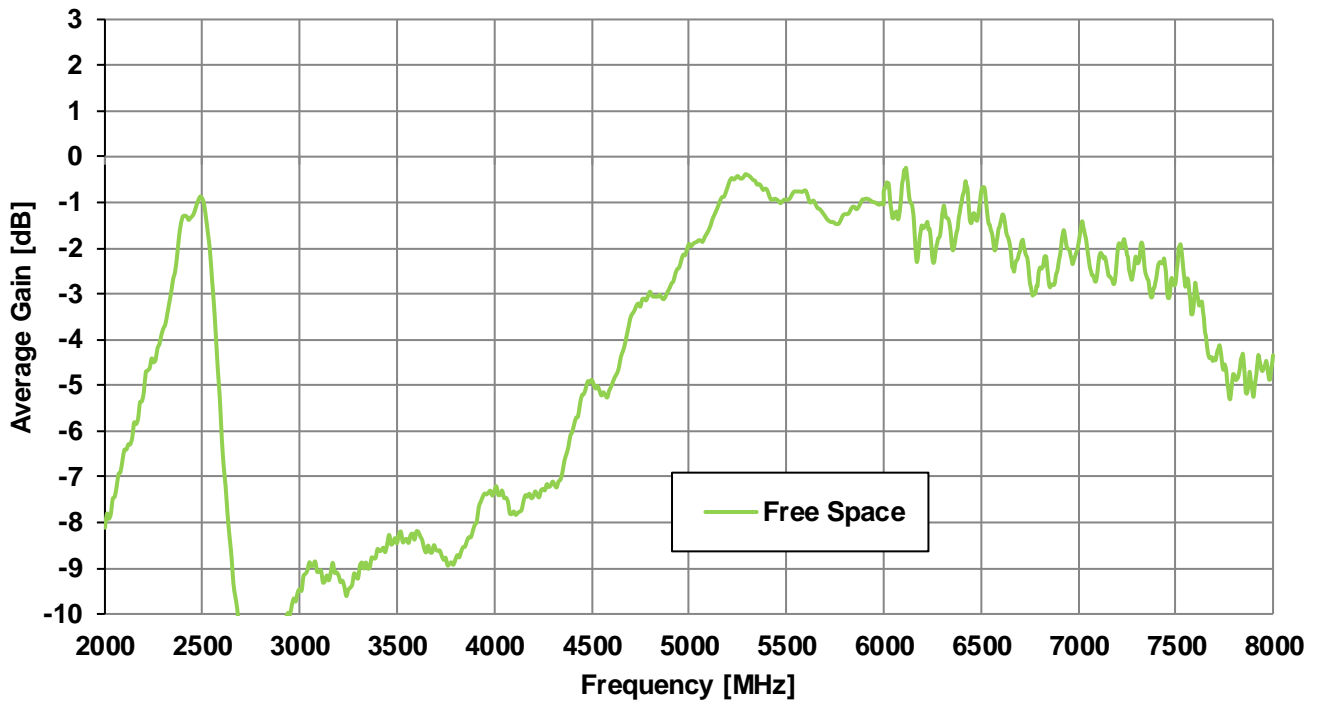

### 3.6 Axial Ratio

Axial Ratio vs Frequency

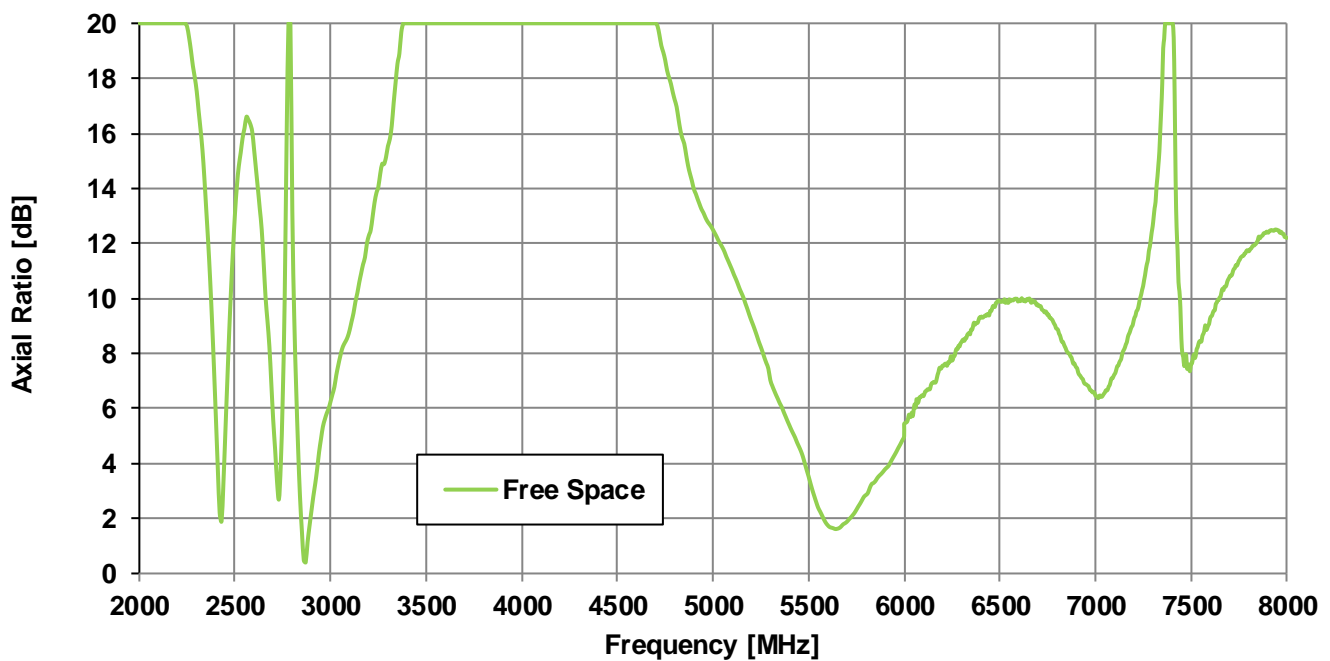

## 4. Radiation Patterns

### 4.1 Test Setup

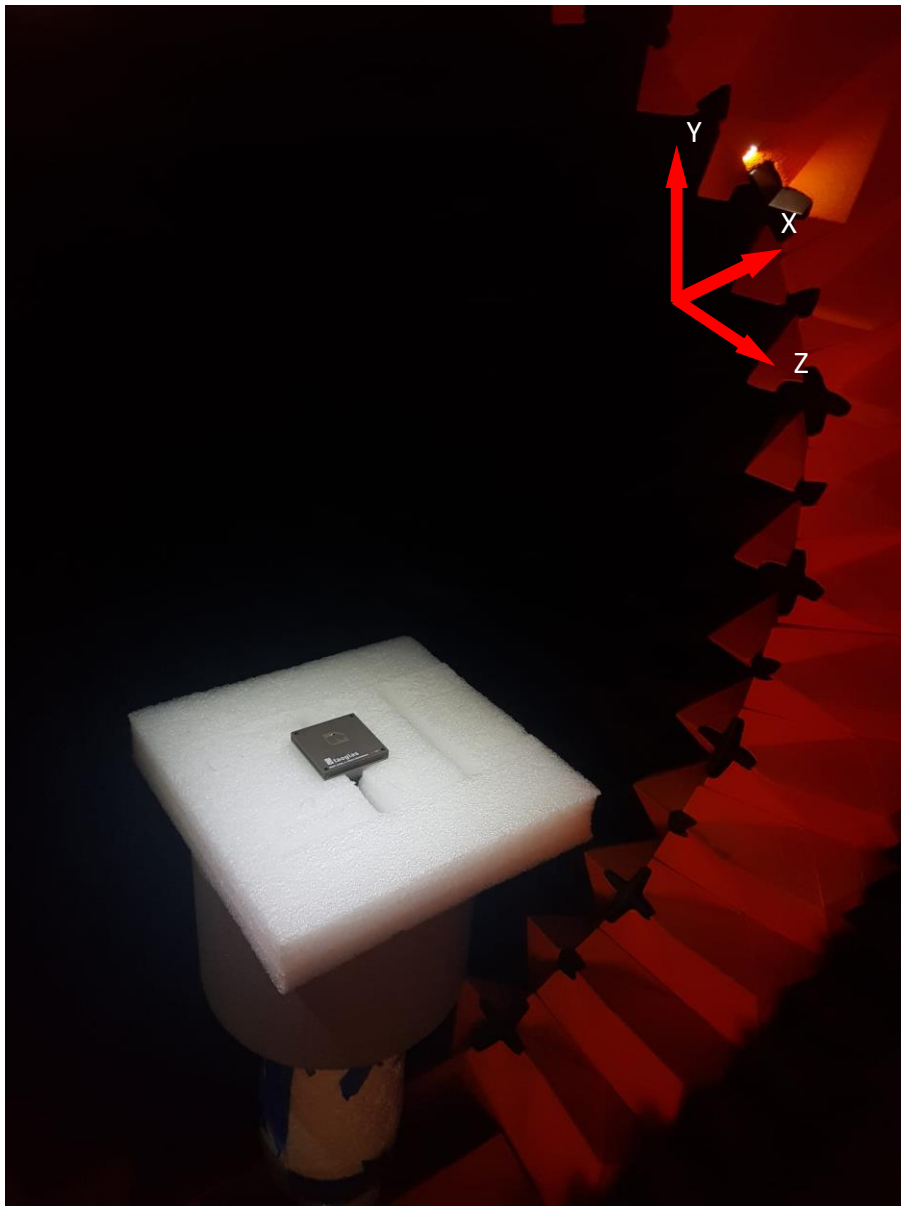

Free space

## 4.2 3D and 2D Radiation Patterns

2450MHz

5550MHz

Azimuth = 0.0  
Elevation = -15.0  
Roll = -45.0

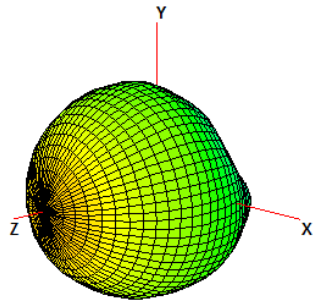

2450 MHz

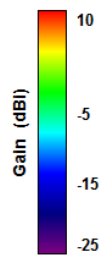

Azimuth = 0.0  
Elevation = -15.0  
Roll = -45.0

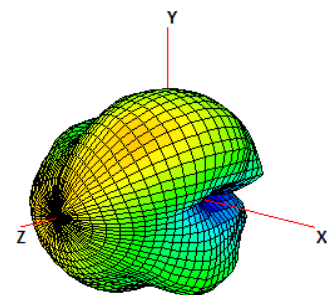

5550 MHz

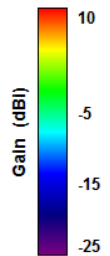

XY Plane

XZ Plane

YZ Plane

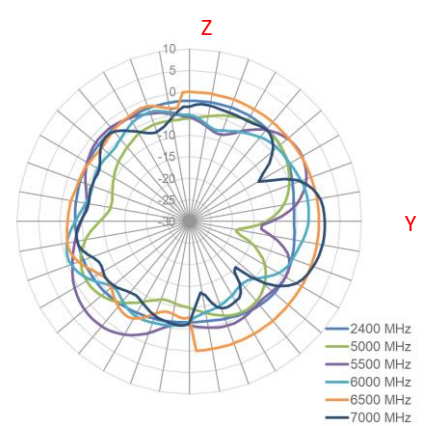
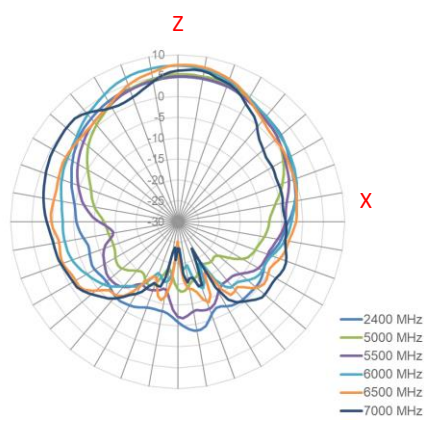
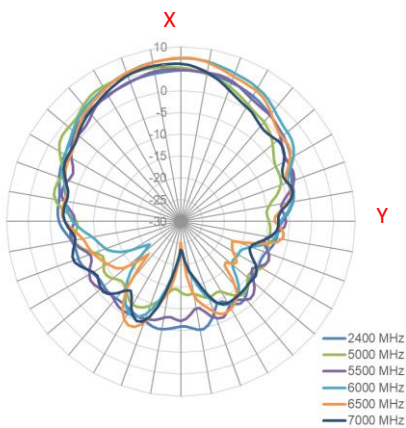

# 5. Mechanical Drawing (Units: mm)

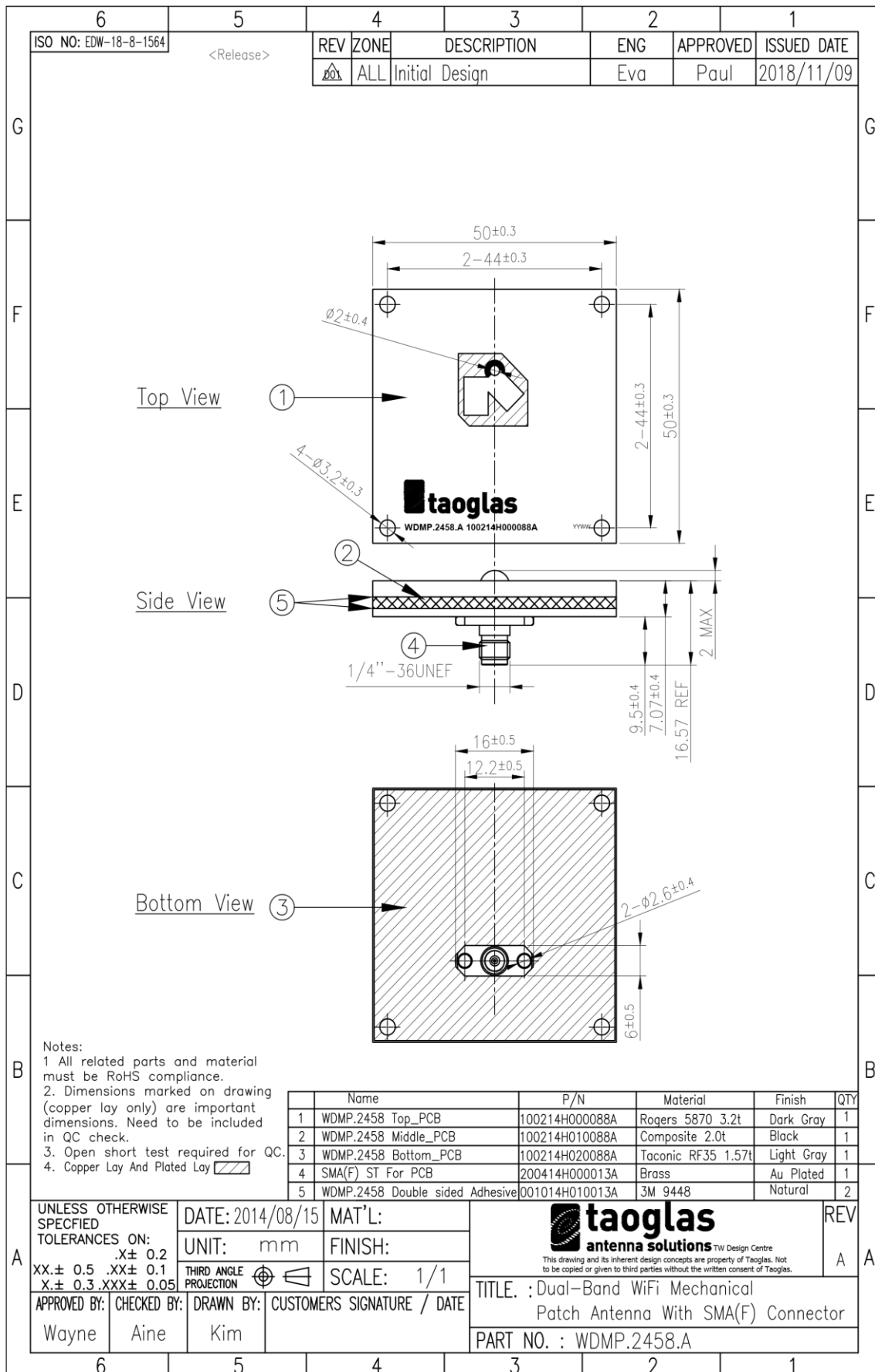

## 6. Installation Instructions

There might be situations where the WDMP.2458.A needs to sit firmly on the device board, either a plastic or a metal board. The patch provides four screw holes for this purpose. This section illustrates the type of screw and screw/connector holes dimension should be considered for installation.

**Screw type:** Non-conductive M3 screw

**Nut type:** Non-conductive HEX M3 nut

**On-board screw holes dimension:**  $\varnothing$  3.2mm

**On-board connector holes dimension:** 18 x 8 mm

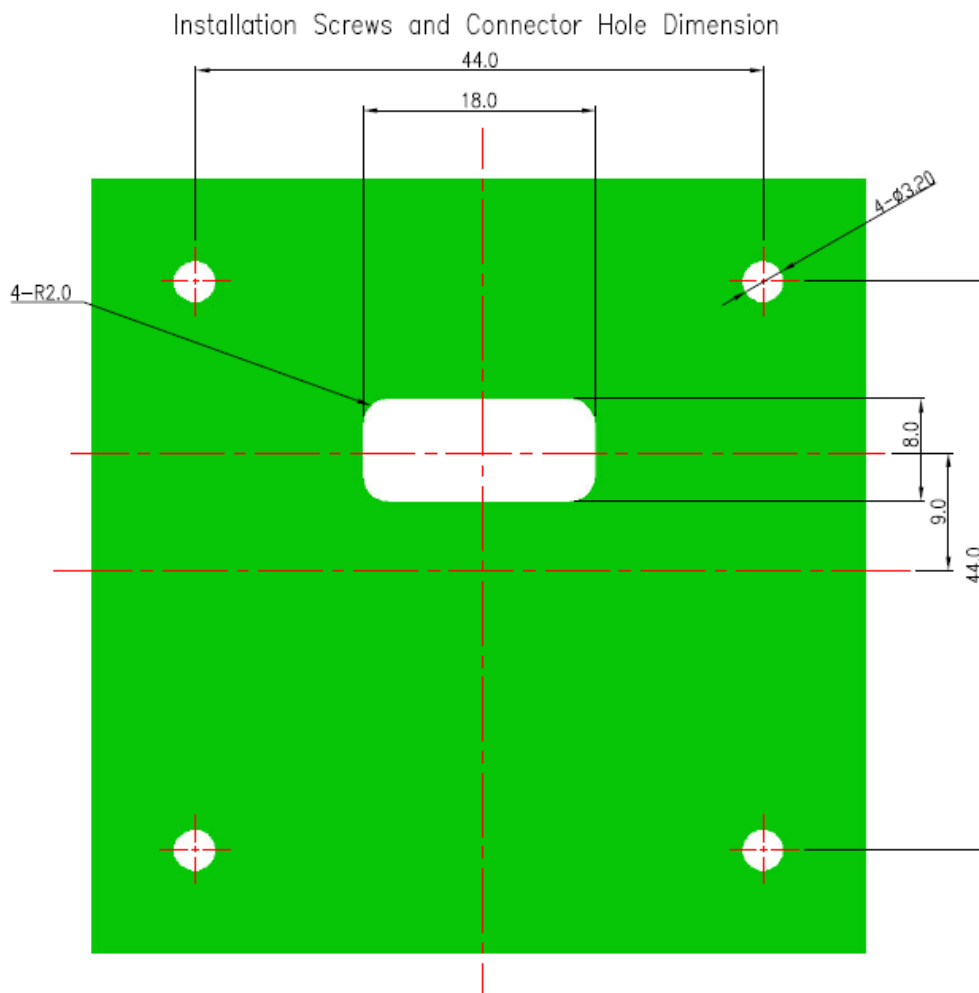

Exploded View

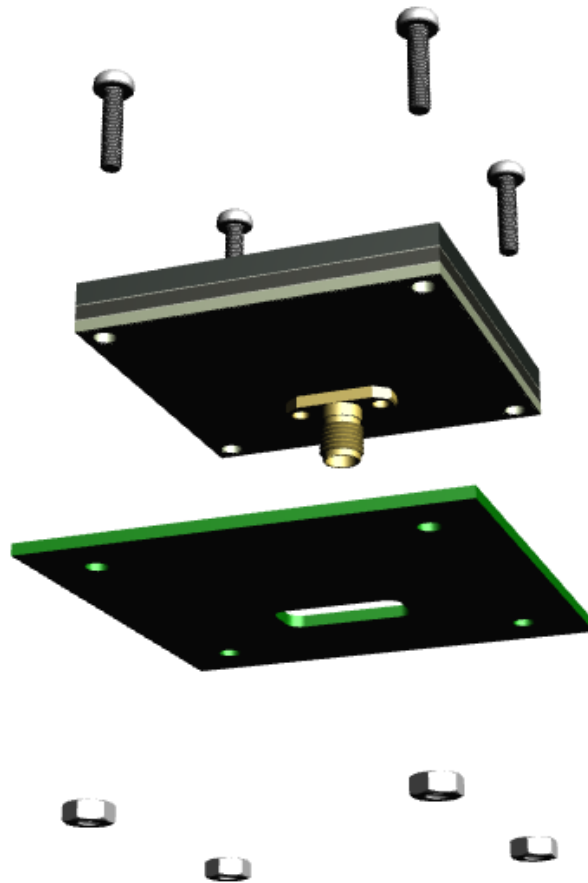

Screw Length Calculation

X = implemented board thickness

$$\text{Screw Length} \geq 7.07 + X + 2.5 (\text{M3 Nut Thickness})$$

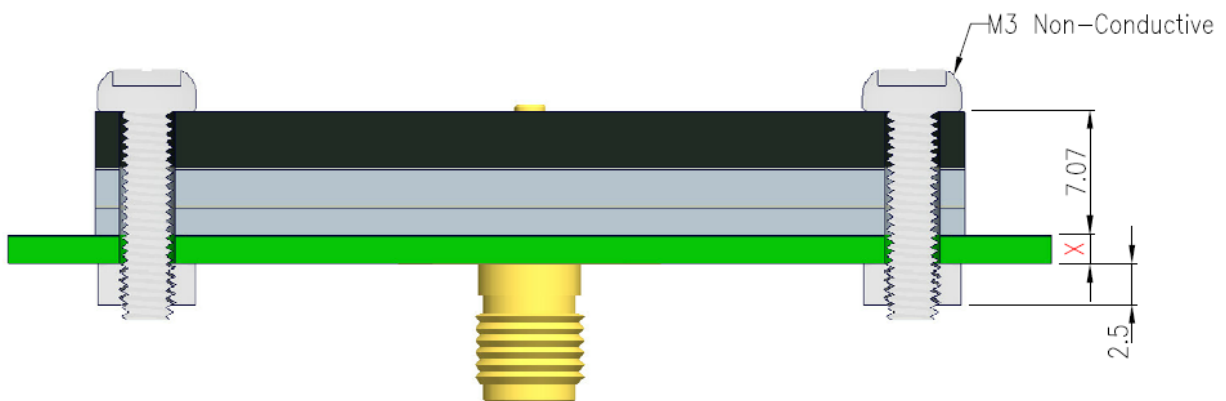



## 7. Packaging

### WDMP.2458.A

#### Packaging Specifications

25 pcs WDMP.2458.A per tray  
 Each tray in vacumed PE bag  
 Tray Dimensions - 340\*340\*27mm  
 Weight - .91Kg per tray

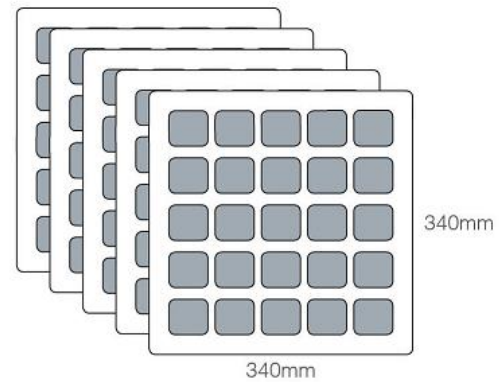

10 Trays per Carton - 250 pcs  
 Carton Dimensions - 360\*360\*310mm  
 Weight - 9.93Kg

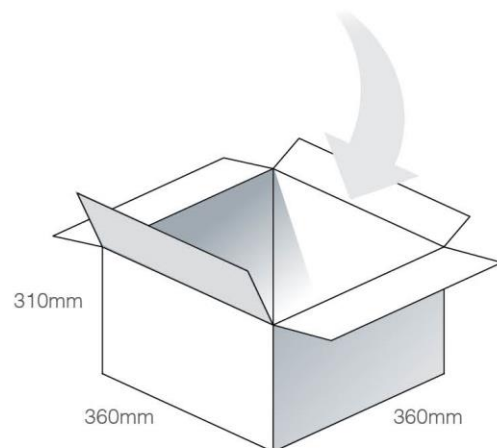

Pallet Dimensions 1100\*1100\*1370mm  
 36 Cartons per Pallet  
 9 Cartons per layer  
 4 Layers

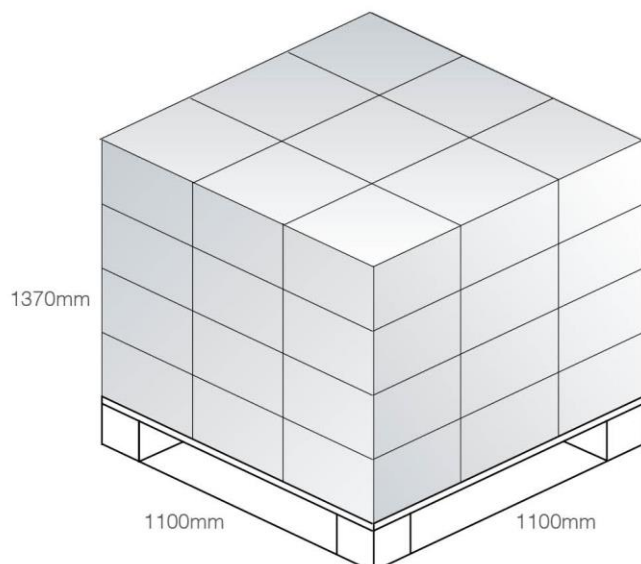

Changelog for the datasheet

**SPE-15-8-046 – WDMP.2458.A**

<b>Revision: B (Current Version)</b>	
Date:	2020-05-25
Changes:	Updated to include W-Fi 6 data
Changes Made by:	Jack Conroy

**Previous Revisions**

<b>Revision: A (Original First Release)</b>	
Date:	2015-08-11
Notes:	
Author:	Technical Writer



**TAOGLAS**®

[www.taoglas.com](http://www.taoglas.com)

