

NSP-7 TECHNICAL SPECIFICATIONS

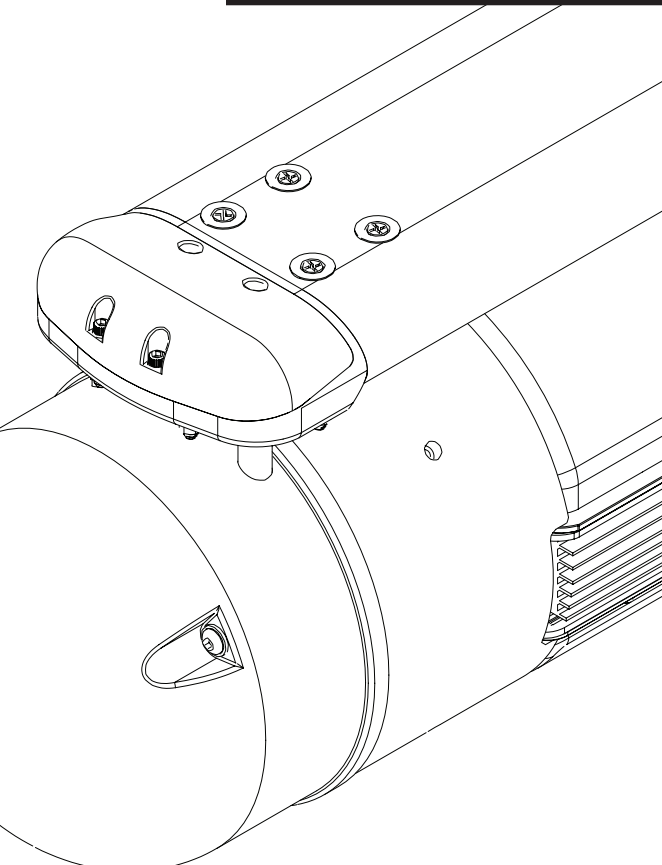

SYSTEM SPECIFICATIONS

SIZE	DIAMETER: 5.4 IN (13.7 CM) LENGTH: 58.1 IN (147.6 CM) HEIGHT: 6.8 IN (17.3 CM)
WEIGHT	24 LBS (10.9 KG)
POWER	275 W
FREQUENCY	KU
OPERATING ALTITUDE	MODE DEPENDENT UP TO 23,000 FT AGL
SENSOR CUING	CURSOR ON TARGET
COMMUNICATION	ETHERNET
COMMAND & CONTROL	LISA 3D™, LISA DASHBOARD™, AND RADAR CONTROL API
IMAGE EXPLOITATION	LISA 3D™ OR EXISTING PED EQUIPMENT
STANDARD DATA PRODUCTS	KML, COMPLEX NITF, JPG, PNG, BMP, STANAG 4607 DETECTS, STANAG 4676 TRACKS

PERFORMANCE DATA

SAR IMAGING	RESOLUTION:	MAX RANGE:	MAX RANGE PIXELS:
	0.3 M	22.5 KM	4,000
	1 M	32 KM	4,000
MOVING TARGET INDICATOR VEHICLE	MAX RANGE:	MAX CONTINUOUS COVERAGE:	
	17 KM	85 KM²	
MARITIME SURVEILLANCE	RANGE:	SWATH WIDTH:	COVERAGE:
RAFT:	9 NMI	8 NMI	1200 NMF/HR
FISHING BOAT:	12.5 NMI	11 NMI	1650 NMF/HR
YACHT:	21 NMI	19.5 NMI	2925 NMF/HR
SMALL TANKER:	41 NMI	38.5 NMI	5775 NMF/HR
SUPER TANKER:	73 NMI	69 NMI	10,350 NMF/HR

CAPABILITY VARIANTS

	NSP-7(S)	NSP-7(P)	NSP-7(X)
IMAGING	SAR	SAR	SAR
CHANGE DETECTION	NON-COHERENT (MCD)	NON-COHERENT (MCD)	NON-COHERENT (MCD)
	---	COHERENT(CCD)	COHERENT(CCD)
MARITIME SURVEILLANCE	STANDARD	ADVANCED	ADVANCED
MOVING TARGET INDICATOR	STANDARD VEHICLES	ADVANCED VEHICLES & DISMOUNTS	ADVANCED VEHICLES & DISMOUNTS
RESOLUTION (METERS)	0.3, 0.5, 1, 2, 5, 10	0.3, 0.5, 1, 2, 5, 10	0.1, 0.3, 0.5, 1, 2, 5, 10

Performance data assumptions: operating altitude 18kft, speed 150ktas



EXTENDED RANGE MULTI-INT SAR/MTI RADAR

In both land and maritime environments, gather actionable intelligence in all weather, day or night, from a turboprop-sized aircraft.

RADAR MADE SIMPLE

SIMPLE TO INTEGRATE

The NSP-7 is a multimode, low-Size, Weight, and Power (SWaP) radar system in a weatherized pod. The NSP-7 pod requires only power, ethernet and a connection to a GPS antenna to operate. It can be attached to an aircraft using MIL-Spec 14" lug mounts or via an adapter plate to the integral mounting points on the NSP-7 strongback rail. IMSAR also has the in-house expertise to design custom integrations for specific platforms when needed.

The NSP-7 can be paired with the Lisa Air or Lisa Air Lite Airborne Processing Server to enable real-time, onboard data processing, or connected to the Lisa GCS Ground Processing Server via a datalink. Radar data can also be stored onboard the NSP-7 for post-mission processing.

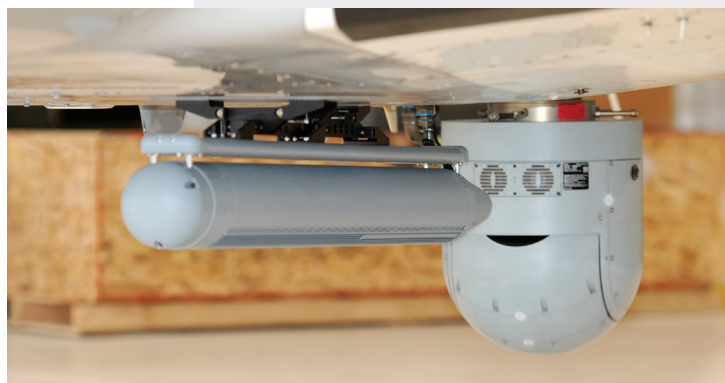
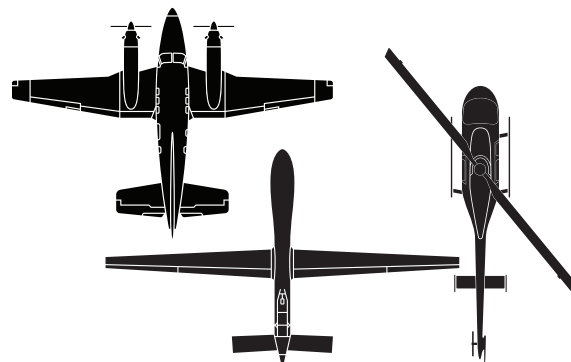

SIMPLE TO UNDERSTAND

Intelligence is everything. The NSP-7 is part of the IMSAR radar ecosystem designed to make it easy to turn radar data into intelligence. It starts with high quality radar data generated by the NSP-7. Then advanced processing techniques are used to create a variety of data products enabling all-weather Intelligence, Surveillance, and Reconnaissance (ISR) and surface search missions. IMSAR's Lisa 3D is an intuitive software tool purpose-built and optimized for radar sensors, with the ability to display

data from complementary sensors like FMV and AIS. In addition, IMSAR radar data products can be output in industry standard formats enabling operators and analysts to use existing tool chains. IMSAR training courses, taught by industry experts, give new and existing users the experience and skills they need to enable mission success.

Go to www.imsar.com for more information about IMSAR's radar capabilities.

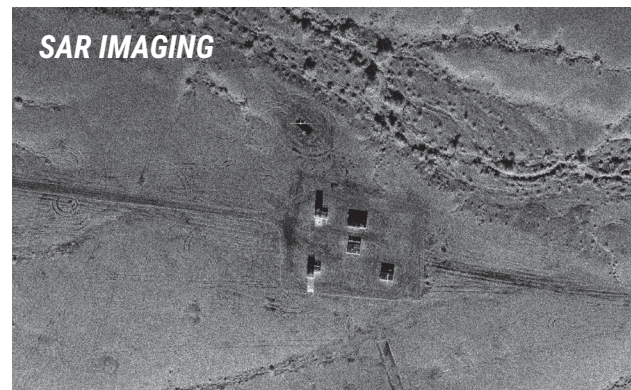

SIMPLE TO OPERATE



The NSP-7 radar system is simple to operate with IMSAR's Lisa 3D Command and Control (C2) and Processing, Exploitation, and Dissemination (PED) software.

Lisa 3D provides graphical and intuitive tools to quickly and easily perform the following functions:

- **Pre-Mission Planning:** Create data collection plans and use them to generate flight plans that can be uploaded to various manned and unmanned flight control systems.
- **Operations:** Monitor and control the radar system; program the radar system to automatically collect SAR, CCD, MTI, or maritime surveillance data; dynamically change data collection plans, flight plans, or data collection modes; and cross cue FMV sensors. Ingest and display real-time data from multiple other sensors, such as AIS and FMV. Perform real-time data analysis to generate actionable intelligence.
- **Post-Mission Analysis:** View and annotate data and export data using the built-in export feature. Run training classes and data forensics on previously collected data.

The NSP-7 can also be controlled through the Radar Control API which enables other software suites to slew the radar to an AOI and immediately begin collecting data, and access data products and system status information.

IMSAR's customer support team is available to help whenever there are questions.

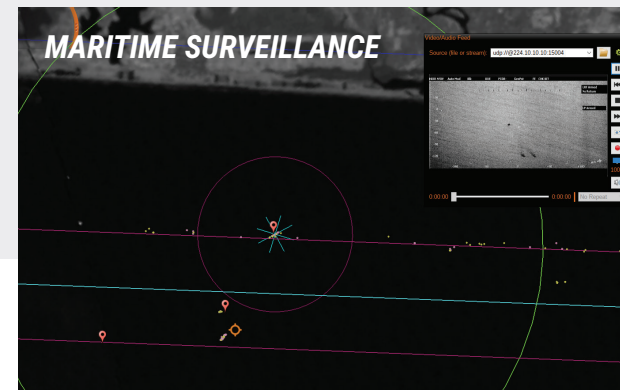

OPERATING MODES

Stripmap - Radar images or monitors a swath of ground parallel to the aircraft's direction of flight.

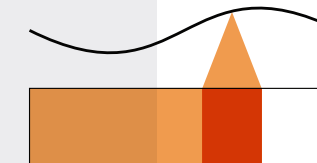

Spotlight - Radar continuously images or monitors a preselected area of ground as the aircraft flies past or around it.

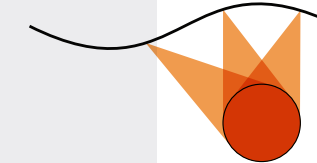

Wide Area - Radar persistently monitors the large area within the radar's field of view for potential targets of interest.

