

Exhibit A - Narrative Statement

Introduction:

Swarm Technologies Inc (“Swarm”) is a California based corporation seeking to demonstrate in the market two-way communications satellites to serve as a cost-effective low-data rate Internet of Things (IoT) network connectivity solution for remote and mobile sensors. The initial experimental space deployment is comprised of four satellites and two ground stations, as already authorized by the FCC¹ and scheduled for launch in April 2018. This new application seeks authorization to deploy two (2) more Swarm operated ground stations and to conduct a market trial study with select participants and the minimum number of participant ground terminals necessary to demonstrate the viability of Swarm’s proposed future architecture.

Each satellite, ground station, and participant ground terminal will use VHF band frequencies for communications. The VHF frequency proposed in this application, more specifically in the 137-138 MHz and 148 - 149.9 MHz bands, is allocated on a primary basis for space to ground Mobile Satellite Service (MSS) communications for non-Federal, non-voice non-geostationary orbit (NGSO) systems and capable of low data rate ground to space and space to ground communications with low power and antenna gain and is ideally suited for Swarm’s proposed satellite based data relay network.

Swarm requests experimental market trial authority to demonstrate the capabilities of these satellites with select end user participants for serving low data rate communication relays for remote sensors and data collectors. Market Trial operations are requested to begin with the initial four satellites currently authorized by the FCC. This authorization request also includes two (2) additional Swarm operated ground stations and up to five-hundred (500) end user ground terminals to be deployed throughout the United States at participant selected locations. The period of the market trial is expected to be one year. If authorized by the commission, Swarm will seek an extension of the aforementioned special temporary authorization for the associated satellites such to match the period of the market trial.

General Description of the Overall System and Operations:

The proposed architecture is comprised of both space and ground units so that collection of ground based remote sensor data, radio relay to space units, and radio relay to Internet connected ground stations ultimately aggregate and disseminate data products effectively to the end user. Figure 1 shows a high level description of the data relay network architecture consisting of end user gateways (up to 500 units), satellites, and internet connected ground stations operated by Swarm. Gateways gather data from end user participant sensors via direct connection, WiFi, and Bluetooth. The same Gateways uplink the participant sensor data to the satellites when within range, where the data is temporarily stored. When commanded, the

¹ See FCC File No. 0026-EX-ST-2018, authorization from March 14, 2018 to September 14, 2018.

satellites downlink the stored participant data to Swarm operated Ground Stations, which pass the data to the end user through the Internet.

Swarm Architecture

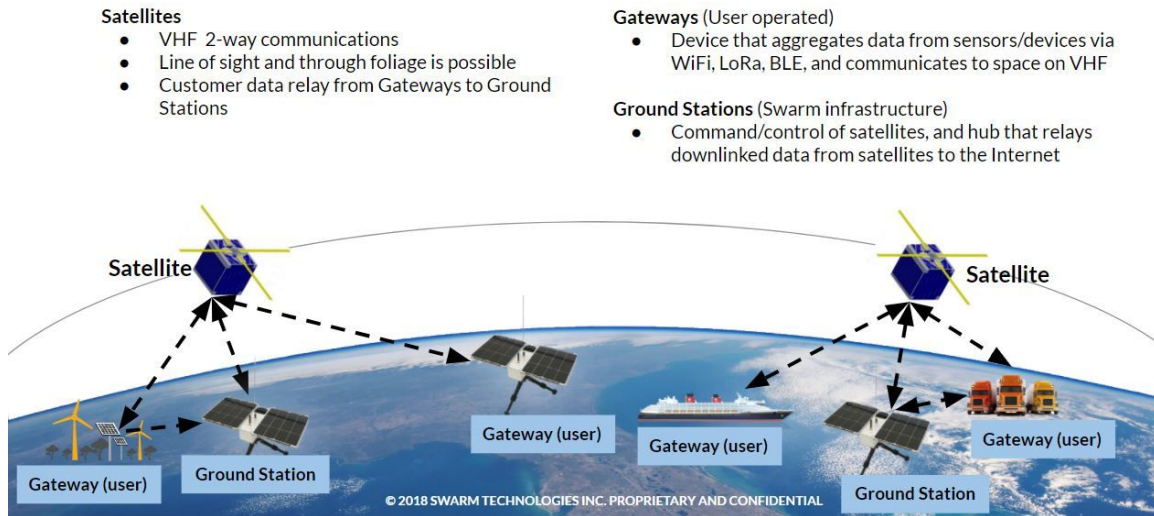

Figure 1: Swarm Data Relay Network Architecture. All Figure 1 Ground Stations and Gateways located within the U.S.

Swarm satellite (Swarm operated)

The Swarm satellites will transmit once per minute over the U.S., and initiate communications from the Gateways or Ground Stations. The Gateways and Ground Stations then communicate back to the satellite, and a successfully transmitted message is acknowledged by the satellite. For data transfer to the satellite, each Gateway and Ground Station uses a random number time offset so that messages do not conflict from multiple Gateways or Ground Stations in view of a satellite. Communications between the satellites and Ground Stations or Gateways are half duplex, such that both uplink and downlink transmissions occur one-way at a time, but on separate frequencies for uplink and downlink (Table 1).

Any satellite transmission can be immediately terminated by ground command if interference is detected or reported. Transmission durations are short and infrequent, with less than a 1% duty cycle averaged over a 15 minute period. Further, each satellite has a hardware and software “dead man’s switch”, which ceases all transmissions every 72 hours. Both of these hardware and software watchdog timers are also triggered if any anomaly is detected onboard the satellite. Transmission from the satellite must be turned back on every 72 hours by command from the ground.

Swarm satellites utilize the 1U Cubesat form factor described in the aforementioned experimental authorization and shown pictorially in Figure 2. The satellites will orient themselves with the VHF antenna wires (quarter-wavelength split dipole, linear polarization) in the zenith and

nadir directions for maximizing the antenna gain along the horizon, which is ideal for long distance communications with ground equipment. The satellites receive participant data from Gateways and store the data on-board for downlink later at the next available internet connected Ground Station.

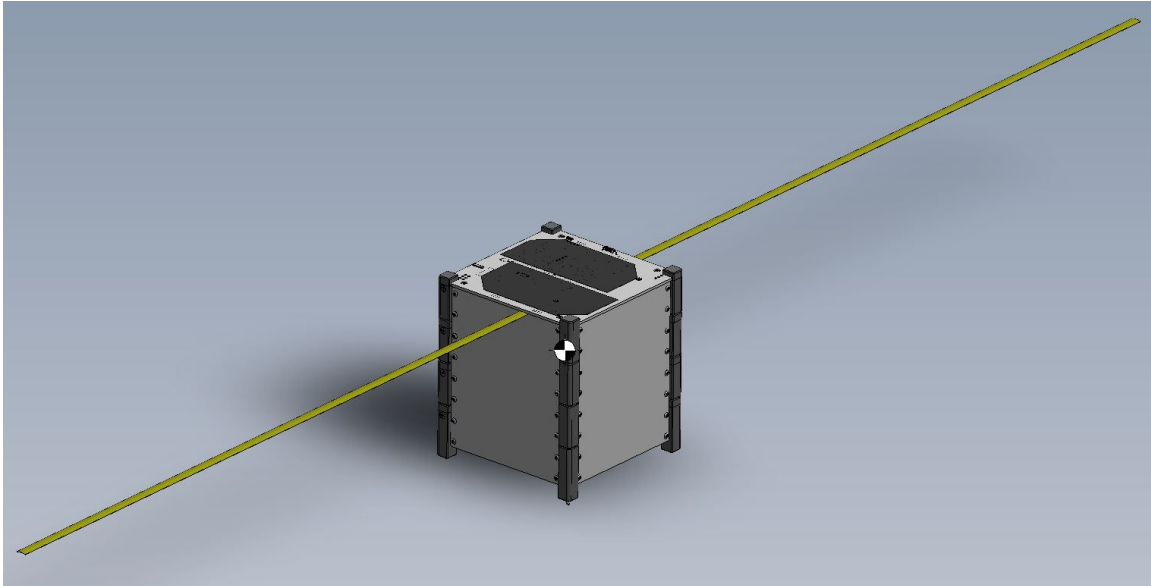

Figure 2: Image of a Swarm satellite.

Ground Stations (Swarm operated)

Swarm internet connected Ground Stations serve encrypted communications (AES 256, for both uplink and downlink) with the satellites for control and management of the constellation. They also receive stored end user participant data from Gateways, which is then passed on to the end user through a Swarm operated Ground Station and then to the Internet.

Gateways (user operated)

End user Gateways are self sufficient devices with solar panels and batteries for power and receive data from nearby remote sensors or cell phones via Wifi, Bluetooth, and other low power mobile communication protocols² and are especially suitable for remote applications. These Gateway devices collect sensor data and uplink the data to the satellites (AES 256 encryption for both uplink and downlink) when the satellites are overhead.

Swarm Ground Stations and end user Gateway's have a similar hardware exterior (antenna, solar panels, batteries) but have different firmware and serve different functions as stated above. Figure 3 shows a picture of a typical Ground Station or Gateway device.

² Part 15 transmitters involved in the proposed tests comply with all applicable emission limits and will be labeled pursuant to Section §2.803(c)(2)(iii) of the Commission's Rules ("This device has not been authorized as required by the rules of the Federal Communications Commission. This device is not, and may not be, offered for sale or lease, or sold or leased, until authorization is obtained.")

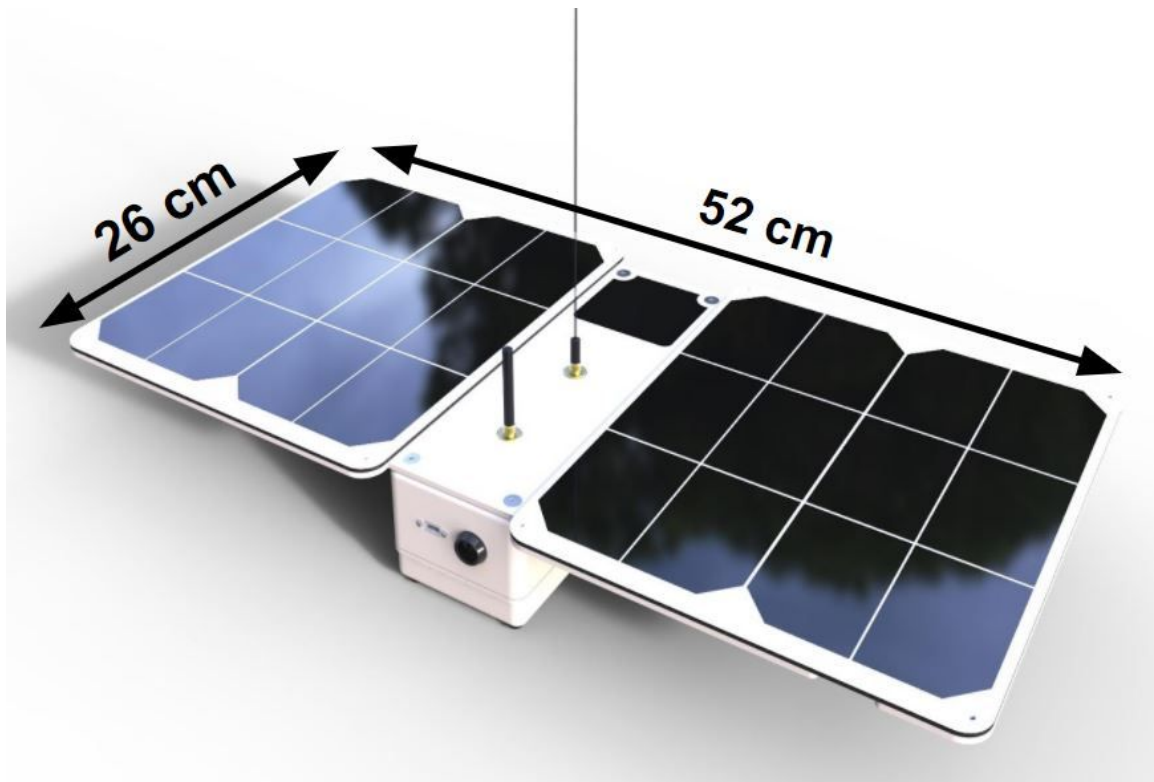

Figure 3: Image of a Swarm Ground Station and Participant Gateway.

Description of the Market Trial Program:

Swarm has spoken with 125+ potential end user participants, including U.S. companies that wish to engage in Market Trials per §5.602 outlined in Subpart H of the Electronic Code of Federal Regulations. Swarm has already partnered with two Fortune 100 companies to conduct field trials (market trials) of the Swarm data relay network and end user ground terminal devices and is detailed in Exhibit B attached to this application.

Public Interest Consideration:

The commission's grant of this application will serve the public interest by allowing Swarm to demonstrate the above described very low-cost satellite based data relay technology, which aims to serve the growing need for a transmission medium to collect and disseminate remote sensor data from anywhere on the Earth at very low cost to the user, including Earth weather data for environmental monitoring. This technology expands market access to low cost remote sensor data networks.

Swarm has partnered with two major companies in paid pilot programs to study the effectiveness of our network architecture with a next phase requiring a trial deployment of participant ground equipment for real data relay and dissemination proofs. Significant market

demand for our data rates and ground hardware from these two large companies exists, and from 15 medium and smaller companies exists if a Swarm space data relay network existed.

In addition to commercial partnerships, we are working with several U.S. Federal agencies on various initiatives. The first is with NASA Ames in a paid grant and hardware delivery services program. NASA wants to test new satellite networking technology that they are developing in collaboration with Swarm. Second, Swarm was recently awarded a National Science Foundation Phase II SBIR grant to develop new network technology to provide very low cost connectivity to commercial and humanitarian efforts around the world. Finally, three other U.S. Federal agencies have expressed interest in the use of Swarm's network services for tracking and geo-locating a large number of items on the ground and at sea.

Non-Interference Criterion:

It is understood that a grant of authority for this experimental program will be on a non-exclusive and non-interference basis to both Federal and non-Federal authorized users of the VHF spectrum proposed in this application. If any interference is detected or reported, our operators will cease transmissions immediately. Swarm maintains an emergency support line as follows:

Emergency Stop Buzzer contact number:
Swarm Technologies POC: Alan Adamson
Cell: 678-549-7881
alan@Swarm-Technologies.com

Radio System Technical Characteristics:

Both satellites and ground equipment share similar antenna and radio frequency characteristics as shown in Table 1.

	Ground to Space	Space to Ground	
Center Frequency	148.500	137.920	MHz
Frequency Tolerance	0.001%	0.002%	
Transmitter Power	0.2	0.2	Watts
Transmitter Power	-7.0	-7.0	dBW
Power Density	-58.0	-58.0	dBW/Hz
Peak Transmit Gain	2.15	2.15	dBi
Max EIRP	-4.84	-4.84	dBW
Bandwidth	125	125	kHz
EIRP Density	-19.79	-19.79	dBW / 4kHz

Table 1: Space and Ground Equipment Transmitter Characteristics.

The space to ground transmissions occur at a center frequency of 137.920 MHz and 125 kHz assigned bandwidth, and ground to space transmissions occur at a center frequency of 148.5 MHz and 125 kHz assigned bandwidth with a maximum power spectral density (PSD) of -19.8 dBW/4kHz. Participant Gateway ground to space transmissions may also occur with lower bandwidth and power within the assigned bandwidth and at the same PSD of -19.8 dBW/4kHz.

The out of band emissions are minimized by digital modulation techniques and filtering with at least 20 dB spectral rolloff at 120% of signal bandwidth in any 4 kHz band, 40 dB at 200% bandwidth, 55 dB at 300% bandwidth, and more than 60 dB beyond 4 times the bandwidth.

The satellite antenna is a ¼ wave dipole with a donut shaped antenna pattern oriented with maximum gain toward the horizons and minimum gain in the nadir direction. The Gateway and Ground stations use a vertically polarized dipole antenna. Figure 4 and Figure 5 show the space and ground antenna patterns and characteristics respectively, applicable for both transmit and receive.

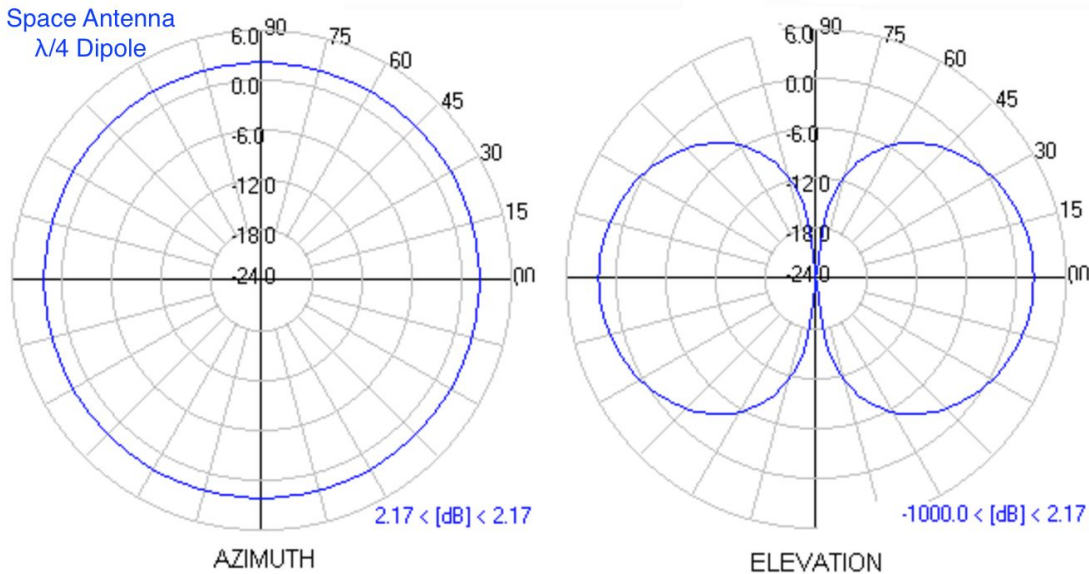

Figure 4: Satellite Transmit and Receive Antenna pattern.

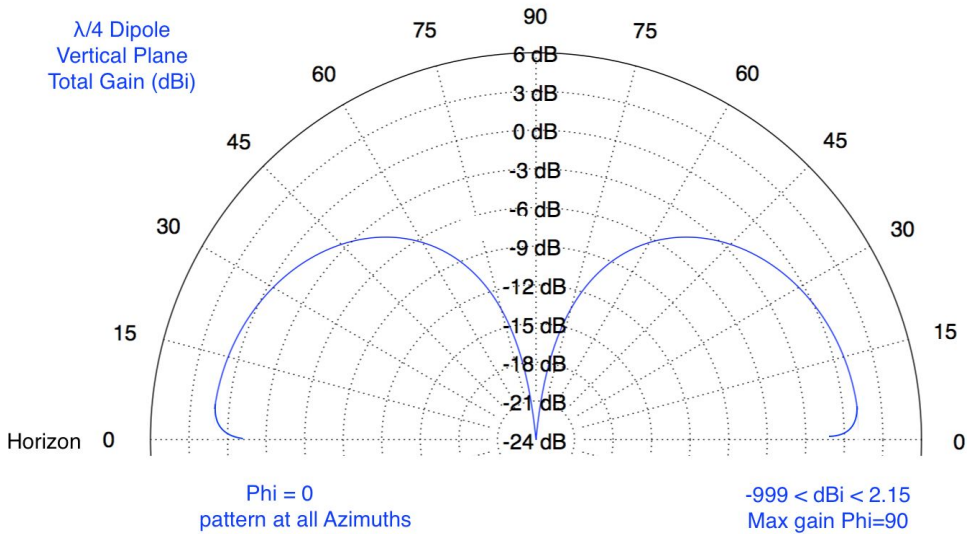

Figure 5: Participant Gateway and Swarm Ground Station Transmit and Receive Antenna Pattern.

All satellite to ground station communications initiate upon command and self terminate at the completion of the data transmission. If any deviation from the authorized technical requirements of the transmission is detected, the ground system will not initiate further transmissions until the deviation is understood and can be corrected.

Previously Authorized Ground Station Locations:

Ground Station 1
321 Camino Al Lago
Menlo Park, CA 94027
lat/long (NAD83): 37.4363, -122.2123, 40m
Antenna height, 3 meters above ground level
Antenna type: VHF vertical dipole

Ground Station 2
4015 Biltmore Cove Way
Buford, GA 30519
lat/long (NAD83): 34.0847, -83.9476, 366m
Antenna height, 3 meters above ground level
Antenna type: VHF vertical dipole

Additional Ground Station Locations requested for Authorization:

Ground Station 3
127 The Ranch Rd.
Del Valle, TX 78617
lat/lon: 30.1091, -97.5833, 188m
Antenna height, 3 meters above ground level
Antenna type: VHF vertical dipole

Ground Station 4
30 Mile Steese Hwy
Fairbanks, AK 99712
lat/long (NAD83): 65.1401, -147.4518, 245m
Antenna height, 3 meters above ground level
Antenna type: VHF vertical dipole