

Orbital Sciences Cygnus Spacecraft

FCC OET File Number 0136-EX-ST-2012
FCC STA Application Summary

Michael Maguire

maguire.michael@orbital.com

+1 (703) 406-5898



Cygnus Summary – STA Application



A Special Temporary Authority (STA) is requested for use by the Orbital Sciences Cygnus spacecraft. First launch of the Cygnus spacecraft (ORB-D1) will occur in 4th quarter 2012.

Cygnus will operate in the 2200 MHz to 2290 MHz band. This band is allocated for Government use.

Cygnus requires the use of the Government band because it will interface with existing Government communications assets, particularly NASA telemetry ground stations and the NASA Tracking and Data Relay Satellite System (TDRSS)

The NASA and commercial ground systems for spacecraft operations service support use the Government S-Band exclusively for telemetry applications: other bands are not supported.

Cygnus Summary – STA Application



- FCC STA Application allows only Fixed or Mobile
 - Cygnus STA Application specifies Mobile
- Cygnus will operate:
 - SPACE OPERATION SERVICE
 - Orbital Elements
 - Semi-Major Axis: 6779.02 km
 - RAAN: 210.373 deg
 - Eccentricity: 0.0004656438
 - Argument of Perigee: 188.616 deg
 - Inclination: 51.601 deg
 - True Anomaly: 296.031 deg
 - Orbit Period: 5400 s

47CFR2.1 – *Space Operation Service*. A radiocommunication service concerned exclusively with the operation of spacecraft, in particular space tracking, space telemetry, and space telecommand.

47CFR2.1 – *Space Station*. A station located on an object which is beyond, is intended to go beyond, or has been beyond, the major portion of the Earth's atmosphere.

- ORB-D1
 - NASA demo flight to International Space Station (ISS)
 - 4th Quarter 2012
- ORB-1 and subsequent missions to follow
- Missions
 - Space operations – Launch plus up to 180 days (maximum)
- STA Request
 - 6 months to cover changes in launch dates
 - Renewals for 6 months each to cover:
 - Launch delays
 - Longer duration missions
 - Subsequent missions

- All missions
 - Launch from NASA Wallops Flight Facility
 - Separate from Antares ~315 seconds after launch
 - Turn on transmitter ~320 seconds after launch
 - Redundant transmitters on spacecraft
 - Inject into 250 x 275 km orbit ~630 seconds after launch
 - Mission to ISS will increase altitude to match ISS at up to ~400 km
 - End of mission Cygnus will de-orbit and burn up over Pacific
- Flight coordinate data will not be available until TBD days prior to launch when the launch window and ISS orbit are known for the mission period.

- Cygnus will not transmit until it separates from the Antares launch vehicle approximately 320 seconds after launch.
- Telemetry transmissions to TDRSS will begin to support early orbit operations after separation.
- Mode 1 (TDRSS) and Mode 3 (Ground Stations) will continue during orbit raising manoeuvres.
- Mode 1, Mode 3 and PROX/PLS operations will continue during operations near the ISS.
- Mode 1 and Mode 3 operations will continue until Cygnus reenters the atmosphere and is destroyed.
- Mode definitions follow

Cygnus Summary – Axis Definitions

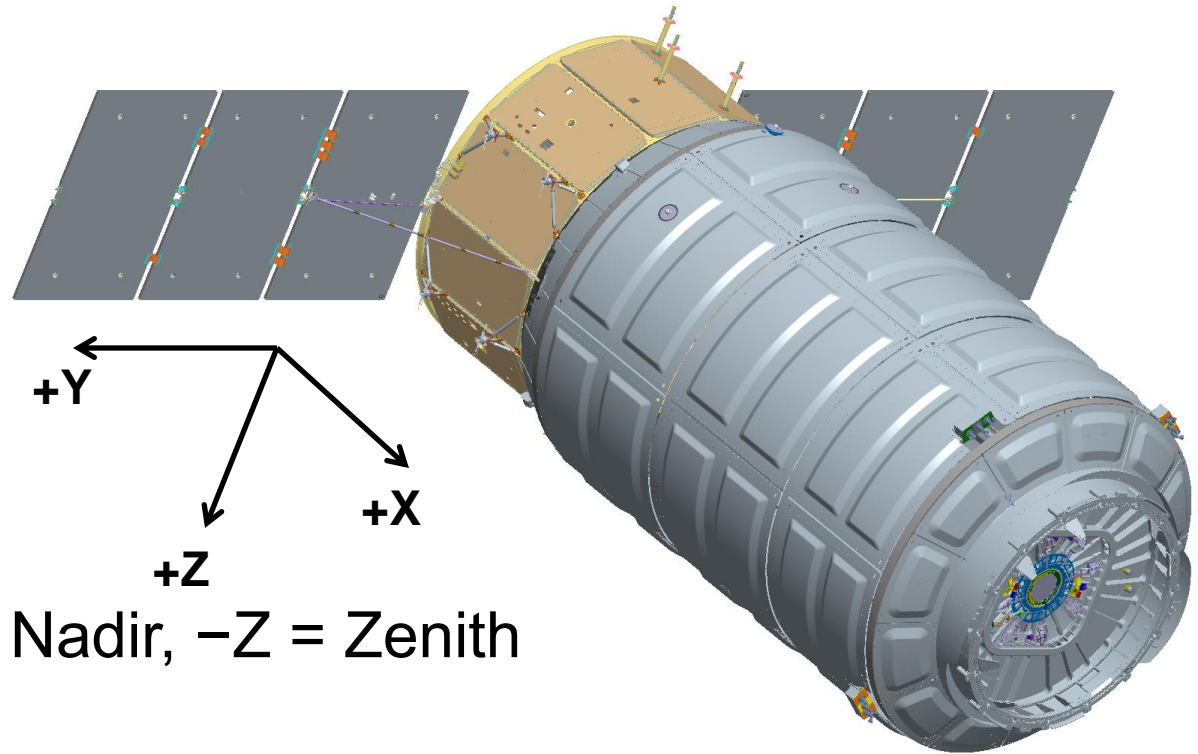

Cygnus: +Z = Nadir, -Z = Zenith

When docked with ISS:

ISS +X = Cygnus +Z

ISS +Y = Cygnus +Y

ISS +Z = Cygnus -X

Cygnus Summary – PROX/PLS Antenna Pattern



PLS Quad/Mono Pair Coupled Omni Antenna
Theta cut plot, Blue Phi = 0 degrees, Violet Phi = 90 degrees

0° corresponds to -Z-Axis where
-Z-Axis is spacecraft zenith

90° corresponds to XY-plane

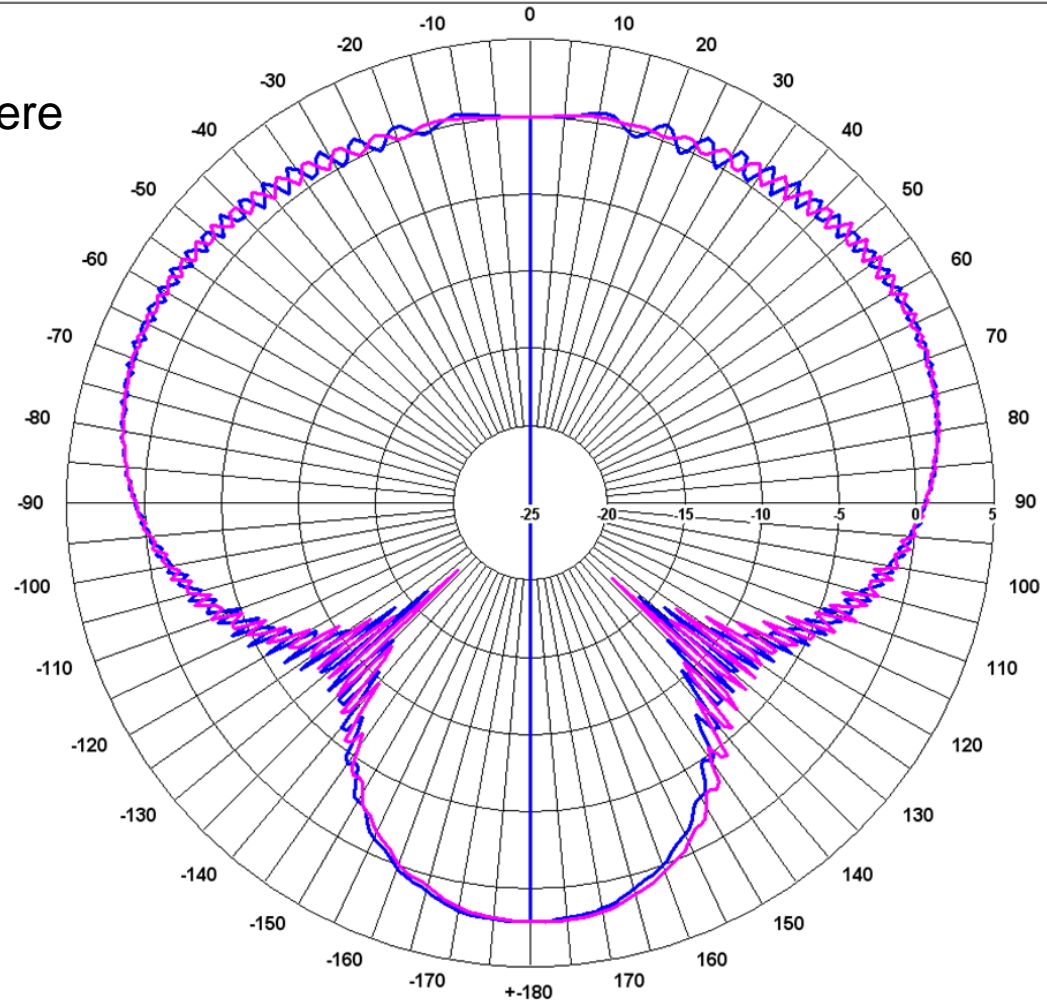

Cygnus Summary – TM Antenna Pattern



Cygnus Telemetry Quad/Quad Pair Coupled Omni Antenna
Theta cut plot, Black Phi = 0 degrees, Blue Phi = 90 degrees

0° corresponds to -Z-Axis where
-Z-Axis is spacecraft zenith

90° corresponds to XY-plane

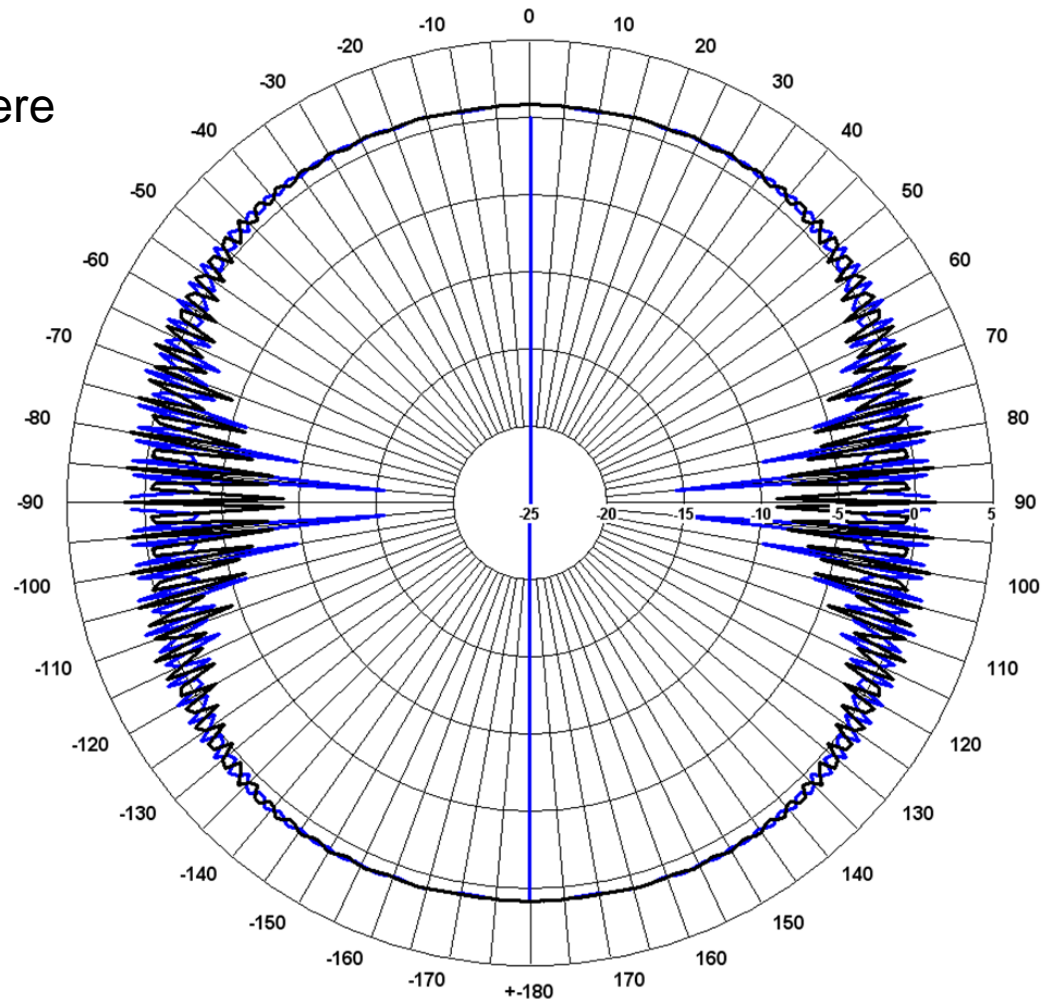

Cygnus Summary – TM Antenna Pattern



Cygnus Telemetry Quad/Quad Pair Coupled Omni Antenna
Theta cut plot, Black Phi = 0 degrees, Blue Phi = 90 degrees

Assuming 350 km altitude ground station will see Cygnus as follows:

- 0° Elevation = $\pm 108.6^\circ$
- 5° Elevation = $\pm 109.2^\circ$
- 10° Elevation = $\pm 111.0^\circ$

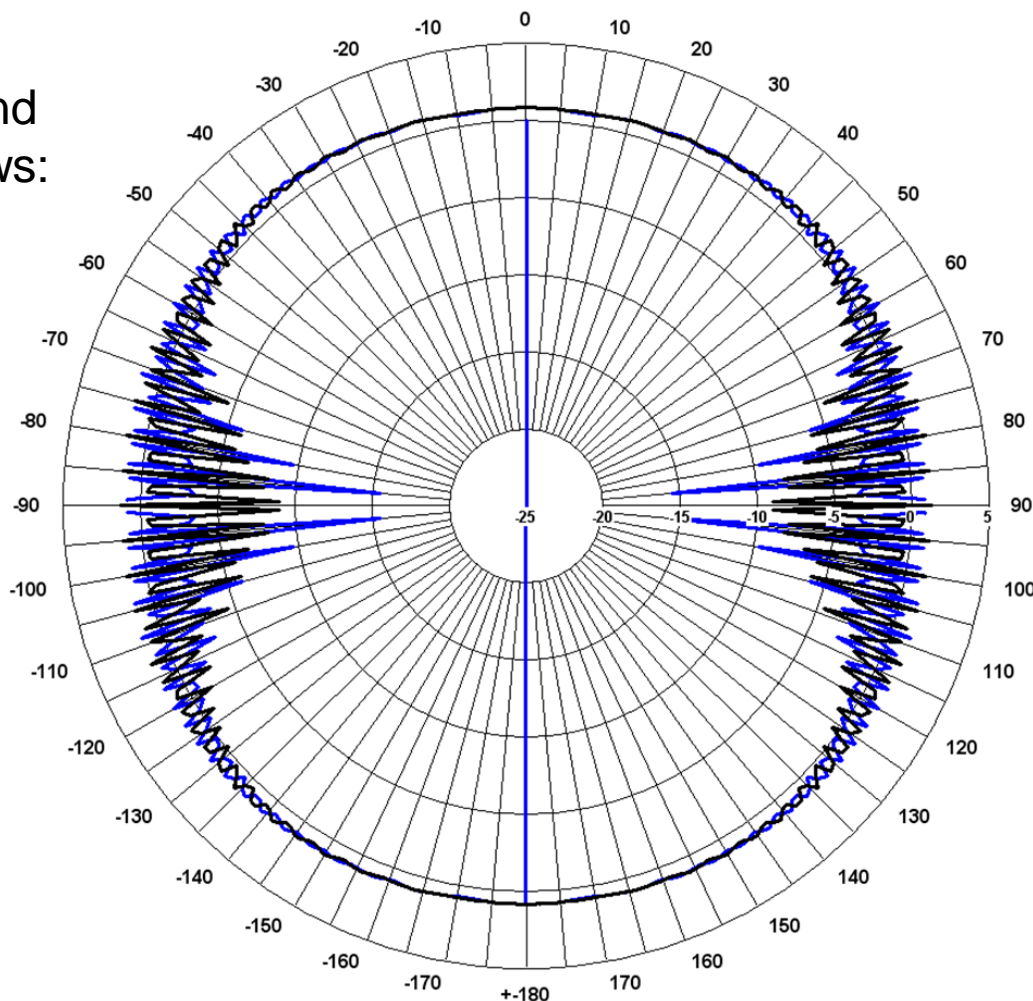

Cygnus Summary – PROX/PLS



- PROX/PLS
 - Proximity Link System (PLS) for ISS communications
 - Space-to-Space data link
 - Operates within 23 km of ISS
- Qty 2 x MELCO transponders
- Frequency
 - Transmit: 2205 MHz
 - Receive: 2030.4375 MHz
 - Frequency fixed by existing PROX system on ISS
- EIRP
 - High Power Mode : -9.7 dBW
 - Low Power Mode : -34.0 dBW
- Modulation: SS-UQPSK
- Chip Rate 2.97 Mchips/second
- Emission Designator: 4M20G1D
- Return Link – JAXA Spread Spectrum
 - 3 MHz chip rate Spread Spectrum UQPSK

Cygnus Summary – PROX/PLS



PROX/PLS use a quasi omnidirectional antenna formed using two passively coupled, circularly polarized, hemispherical low gain antennas, one on the zenith and one on the nadir side of the spacecraft (Z-Axis).

The zenith antenna (-Z-Axis) uses the direct signal path and has greater gain than the nadir antenna. The zenith antenna also has a shaped pattern to provide higher gain during the approach to the ISS.

The nadir antenna uses the coupled signal path resulting in lower antenna gain.

The null plane of the antenna pattern will be in the spacecraft XY plane.

The maximum gain of the PROX/PLS antenna is 3 dBi however the PLS signal power is low (2.09 dBW) resulting in -9.7 dBW EIRP. Also, the pattern is directed to spacecraft zenith.

Cygnus Summary – TM Transmitters



- Return links
 - Spacecraft operations
 - TDRSS Space-to-Space
 - Ground Space-to-Earth
- Qty 2 x Thales transmitters
- Frequency: 2216 MHz
 - Frequency provided by NASA
- EIRP: 8.0 dBW
- TM Mode 1
 - TDRSS S-Band Single Access
 - Spread Spectrum
 - Modulation: SQPN
 - Chip Rate: 2.98 Mchips/second
 - Emission Designator: 6M00G1D
- TM Mode 2
 - TDRSS S-Band Single Access
 - Non-Spread Spectrum
 - Modulation: SQPSK
 - Bandwidth: 8/16/32/42 kHz
 - Emission Designator: 42K0G1D
- TM Mode 3
 - S-Band Ground
 - Non-Spread Spectrum
 - Modulation: SQPSK
 - Bandwidth: 8/16/32/42/3000 kHz
 - Emission Designator: 3M00G1D

The TT&C return (telemetry) links will use an omnidirectional antenna formed using two coupled, circularly polarized, hemispherical low gain antennas, one on the zenith and one on the nadir side of the spacecraft (Z-Axis).

The null plane of the antenna pattern will be in the spacecraft XY plane.

The maximum gain of the omnidirectional antenna is +2.8 dBi. No directional or high gain antennas are employed. This gain represents the maximum antenna gain towards TDRSS and towards ground stations.

The minimum ground station elevation angle for receipt of Cygnus telemetry (return) links will be 0° .

The minimum ground station elevation angle for telecommand (forward) links will be per 47CFR25.204.