

Federal Communications Commission  
Office of Engineering and Technology  
Laboratory Division

April 30, 2014

Public Draft for Review

**Laboratory Division Draft Publication Report**

**Title:** Compliance measurement procedures for U-NII with DFS

**Short Title:** U-NII DFS

**Reason:** Adding attachment D02 and D06 to update KDB to address recently revised rules for U-NII devices.

**Publication:** 905462

**Keyword/Subject:** U-NII, DFS, 15 Subpart E

-----  
**Question:** What is the test guidance to demonstrate compliance for UNII devices subject to DFS requirements?

**Answer:**

The Commission revised the rules for U-NII devices (FCC 14-30) operating under Part 15 (referred to in this document as new rules). These rules will be effective on June 2, 2014.

This KDB Publication with its current final attachments, draft attachments and other related KDBs have been prepared to provide guidance for various test procedures to demonstrate compliance with the new rules. The Commission has established a transition period for the new rules after the effective date. During this period devices may be approved under different rules subject to the following conditions:

- New devices or permissive changes on previously approved devices will be permitted under the previous rules (rules prior to the effective date of FCC 14-30) for one year after June 2, 2014.
  - Devices approved under the rules effective from June 2, 2014 must apply all the appropriate test procedures for such devices and provide software security documentation referenced in this guidance. This also applies to applications for permissive change of previously approved devices seeking to use the provisions of the new rules.
  - All devices approved under previous rules shall not be marketed after June 2, 2016.
  - After June 2, 2016, no permissive changes will be permitted for devices approved under the previous rules unless they meet the requirements of the new rules.
- A. New and permissive change applications for devices based on **U-NII rules prior to the effective date (June 2 2014)** must use the following specific KDB guidance procedures as well as all the general guidance documents:

1. **KDB Publication 905462 D01 - UNII DFS Compliance Procedures Expires 2015 v01** is the proposed attachment to be used for all master devices including devices operating in bridge modes, mesh configurations, hotspot modes, etc under the previous rules. This document is a redesignation of currently published KDB 905462 5 GHz UNII DFS Compliance Procedures.
  2. **KDB Publication 848637** – Current guidance for Client Device that must be used for U-NII client devices without radar detection capabilities.
  3. **KDB Publication 594340** – Current guidance for test modes for DFS master devices.,
  4. **KDB Publication 443999** – Interim Guidance for U-NII devices with radar detection capabilities and operating in the 5470 – 5725 MHz band.
  5. **KDB Publication 594280 D01 - Software Configuration Control v01r02** for non-SDR devices.
  6. **KDB Publication 905462 D05 - 802.11 Channel Plans Expires 2015 v01** is the proposed attachment for the channel plan under the previous rules. It is based on the current attachment in KDB 905462 5802 11 Channel Plan in relation to FCC rules.
- B. Applications for new devices and permissive change applications for devices based on the **new U-NII rules after the effective dates** must use the following specific KDB guidance procedures:
1. **KDB Publication 905462 D02 - UNII DFS Compliance Procedures Effective 2014 v01** is the proposed attachment to be used for all master devices including devices operating in bridge modes, mesh configurations, hotspot modes, etc under the new rules.
  2. **KDB Publication 789033 D02 - U-NII EMC Testing Guidance Procedure v01** must be used to demonstrate compliance with overall EMC standards.
  3. **KDB Publication 905462 D03 - UNII Clients Without Radar Detection Effective 2014 v01** is the proposed attachment to be used to demonstrate compliance with overall EMC standards. It will be redesignation of the current KDB Publication 848637.
  4. **KDB Publication 905462 D04 – Operational Modes for DFS Testing Effective 2014 v01** is the proposed guidance for test modes for DFS master devices. It will be redesignation the current KDB Publication 594340 .
  5. **KDB Publication 594280 D01 - Software Configuration Control v01r02** for non-SDR devices.
  6. **KDB Publication 594280 D02** – Software Security Description Guidance. This guidance must also be used for any application for permissive change applications under the new rules.
  7. **KDB Publication 905462 D06 - 802.11 Channel Plans Effective 2014 v01** is the proposed attachment for the channel plan under the new rules.
- C. The KDB Guidance procedures described in A. and B. above must be applied as a group, it is not permissible to mix and match the guidance documents.

This KDB draft proposes to merge several previous KDB guidance publications related to devices operating in the U-NII band. The revised KDB Publication 905462 is proposed to have the following attachments:

- 905462 D01 UNII DFS Compliance Procedures Expires 2015 v01
  - This procedure will expire June 2 2015. It is currently published in KDB 905462 and will be published as an update and given a D01 document identification. It is not included in this draft for comment.
- 905462 D02 UNII DFS Compliance Procedures Effective 2014 v01
  - **This procedure is new adopted by 1<sup>st</sup> R&O (Docket 13-39, FCC 14-30), effective June 2 2014 and included below for comment.**
- 905462 D03 – UNII Clients Without Radar Detection Effective 2014 v01
  - This procedure is currently in KDB 84637 and is proposed to be published as an attachment KDB 905462 D03 for the new rules. It is not included in this draft for comment.
- 905462 D04 – Operational Modes for DFS Testing Effective 2014 v01
  - This procedure is currently in KDB 594340 and is proposed to be published as an attachment KDB 905462 D04 for the new rules . It is not included in this draft for comment.
- 905462 D05 – 802.11 Channel Plans Expires 2015 v01
  - This channel plan will expire June 2 2015. It is currently published in 905462 and will be updated and given a D05 document identification . It is not included in this draft for comment.
- 905462 D06 – 802.11 Channel Plans effective 2014 v01.
  - **This channel plan is new for 1st R&O (Docket 13-39, FCC 14-30) and included below for comment.**

**Attachment List:**

905462 D01 UNII DFS Compliance Procedures Expires 2015 v01  
905462 D02 UNII DFS Compliance Procedures Effective 2014 v01  
905462 D03 UNII Clients Without Radar Detection Effective 2014 v01  
905462 D04 Operational Modes for DFS Testing Effective 2014 v01  
905462 D05 802.11 Channel Plans Expires 2015 v01  
905462 D06 802.11 Channel Plans Effective 2014 v01

**Federal Communications Commission  
Office of Engineering and Technology  
Laboratory Division**

April 30, 2014

**COMPLIANCE MEASUREMENT PROCEDURES FOR UNLICENSED-NATIONAL  
INFORMATION INFRASTRUCTURE DEVICES OPERATING IN THE 5250-5350 MHz  
AND 5470-5725 MHz BANDS INCORPORATING DYNAMIC FREQUENCY  
SELECTION**

**1. INTRODUCTION**

This document describes the compliance measurement procedures including acceptable instrument system configurations for performing *Dynamic Frequency Selection* (DFS) tests under FCC Part 15 Subpart E Rules required for Unlicensed –National Information Infrastructure (U-NII) equipment that operates in the frequency bands 5250 MHz to 5350 MHz and/or 5470 MHz to 5725 MHz. This DFS test procedure document has been updated to incorporate the changes adopted in the First Report and Order (Docket 13-49, FCC 14-30).

**2. SCOPE**

The scope of this document includes applicable references, definitions, symbols and abbreviations with an overview of the DFS operational requirements, test signal generation and methods of measuring compliance. The methods include calibration and test procedures for conducted and radiated measurements. Either conducted or radiated testing may be performed. Equipment with an integral antenna may be equipped with a temporary antenna connector in order to facilitate conducted tests. When the antenna cannot be separated from the device and a radio frequency (RF) test port is not provided, radiated measurements will be performed.

General information about radio device compliance testing facilities and measurement techniques are assumed to be known and not covered here.

**3. REFERENCES**

- [1] Recommendation ITU-R M.1652
- [2] ITU Resolution 229 (WRC-03)

**4. DEFINITIONS, SYMBOLS AND ABBREVIATIONS**

For the purposes of the present document, the following terms and definitions apply.

**4.1 Definitions**

**Access Point (AP):** A U-NII transceiver that operates either as a bridge in a peer-to-peer connection or as a connector between the wired and wireless segments of the network (§15.403(a)) .

**Association:** An active relationship between two wireless devices in which one device (referred to as a *Master Device* in this document) exercises certain control functions over other devices (referred to as a *Client Device* in this document).

**Available Channel:** A *Channel* on which a *Channel Availability Check* has not identified the presence of a *Radar Waveform*.

**Burst:** A series of radio wave pulses defined by pulse width, pulse repetition interval, number of pulses, and modulation to simulate radar transmissions.

**Channel:** Amount of spectrum utilized by a *Master Device* and any associated *Client Device(s)*.

**Channel Availability Check:** A DFS function that monitors a *Channel* to determine if a *Radar Waveform* above the *DFS Detection Threshold* is present.

**Channel Availability Check Time:** The period of time during which a *Channel Availability Check* is performed.

**Channel Closing Transmission Time:** The total duration of transmissions, consisting of data signals and the aggregate of control signals, by a U-NII device during the *Channel Move Time*.

**Channel Move Time:** The time to cease all transmissions on the current *Channel* upon detection of a *Radar Waveform* above the *DFS Detection Threshold*.

**Client Device:** A U-NII device operating in *Client Mode*.

**Client Mode:** Operating mode in which the transmissions of the U-NII device are under control of the *Master Device*. A U-NII device operating in *Client Mode* is not able to initiate a network.

**Dynamic Frequency Selection:** An interference mitigation technique for U-NII devices to avoid co-channel operations with radar systems.

**In-Service Monitoring:** A DFS function that monitors the *Operating Channel* for the presence of a *Radar Waveform* above the *DFS Detection Threshold*.

**DFS Detection Threshold:** The required detection level defined by a received signal strength (RSS) that is greater than a specified threshold, within the *U-NII Detection Bandwidth*.

**Master Device:** A U-NII device operating in *Master Mode*.

**Master Mode:** Operating mode in which the U-NII device has the capability to transmit without receiving an external control signal and can perform *Network Initiation*.

**Network Initiation:** The process by which the *Master Device* sends control signals to *Client Device(s)* that allow them to begin transmissions.

**Non-Occupancy Period:** The time during which a *Channel* will not be utilized after a *Radar Waveform* is detected on that *Channel*.

**Operating Channel:** Once a U-NII device starts to operate on an *Available Channel* then that *Channel* becomes the *Operating Channel*.

**Radar Waveform:** A *Burst* or series of *Bursts* designed to simulate a radar signal.

**U-NII Device:** Intentional radiators operating in the frequency bands in the 5150-5350 MHz and 5470-5825 MHz that use wideband digital modulation techniques and provide a wide array of high data rate mobile and fixed communications for individuals, businesses, and institutions.

**U-NII Detection Bandwidth:** The contiguous frequency spectrum over which a U-NII device detects a *Radar Waveform* above the *DFS Detection Threshold*.

## 4.2 Symbols

For the purposes of this document, the following symbols apply:

ATT	Attenuator
B	Number of Bins
Burst_Count	The number of <i>Bursts</i> within a single 12 second Long Pulse radar (waveform 5)
Ch <sub>r</sub>	Channel occupied by a radar
D	Distance
Dwell	Dwell time per bin
G	Antenna gain (dBi)
N	Number of spectrum analyzer bins showing a U-NII transmission
F <sub>H</sub>	Highest frequency at which detection occurs above the required value during the <i>U-NII Detection Bandwidth</i> test.
F <sub>L</sub>	Lowest frequency at which detection occurs above the required value during the <i>U-NII Detection Bandwidth</i> test.
P <sub>d1</sub>	Percentage of Successful Detections for Waveform 1
P <sub>d2</sub>	Percentage of Successful Detections for Waveform 2
P <sub>d3</sub>	Percentage of Successful Detections for Waveform 3
P <sub>d4</sub>	Percentage of Successful Detections for Waveform 4
P <sub>dN</sub>	Percentage of Successful Detections for Waveform N
S	Sweep Time
T <sub>channel_avail_check</sub>	The 60 second time period required for the <i>Channel Availability Check</i>
T <sub>power_up</sub>	Amount of time it takes a U-NII device to turn on, initialize, and then begin <i>Channel Availability Check</i>
T <sub>0</sub>	Time instant
T <sub>1</sub>	Time instant
T <sub>2</sub>	Time instant
T <sub>3</sub>	Time instant

## 4.3 Abbreviations

For the purposes of this document, the following abbreviations apply:

ALC	Automatic Level Control
AWG	Arbitrary Waveform Generator
CW	Continuous Wave
DFS	Dynamic Frequency Selection
EIRP	Equivalent Isotropic Radiated Power

FM	Frequency Modulation
IF	Intermediate Frequency
IL	Insertion Loss
IP	Internet Protocol
LO	Local Oscillator
MHz	Megahertz
msec	Millisecond
PRI	Pulse Repetition Interval
RDD	Radar Detection Device
RF	Radio Frequency
RMS	Root Mean Square
UUT	Unit Under Test
U-NII	Unlicensed National Information Infrastructure
µsec	Microsecond
VSA	Vector Signal Analyzer
VSG	Vector Signal Generator

## 5. TECHNICAL REQUIREMENTS FOR DFS IN THE 5250-5350 MHz AND 5470-5725 MHz BANDS

### 5.1 DFS Overview

A U-NII network will employ a DFS function to detect signals from radar systems and to avoid co-channel operation with these systems. This applies to the 5250-5350 MHz and/or 5470-5725 MHz bands.

Within the context of the operation of the DFS function, a U-NII device will operate in either *Master Mode* or *Client Mode*. U-NII devices operating in *Client Mode* can only operate in a network controlled by a U-NII device operating in *Master Mode*.<sup>1</sup>

Tables 1 and 2 shown below summarize the information contained in sections 5.1.1 and 5.1.2.

---

<sup>1</sup> Networks Access Points with Bridge and/or MESH modes of operation are permitted to operate in the DFS bands but must employ a DFS function. The functionality of the Bridge mode must be validated in the DFS test report. Devices operating as relays must also employ DFS function. The method used to validate the functionality must be documented and validation data must be documented. MESH mode operational methodology must be submitted in the application for certification for evaluation by the FCC.



**Table 1: Applicability of DFS Requirements Prior to Use of a Channel**

Requirement	Operational Mode		
	Master	Client Without Radar Detection	Client With Radar Detection
<i>Non-Occupancy Period</i>	Yes	Not required	Yes
<i>DFS Detection Threshold</i>	Yes	Not required	Yes
<i>Channel Availability Check Time</i>	Yes	Not required	Not required
<i>U-NII Detection Bandwidth</i>	Yes	Not required	Yes

**Table 2: Applicability of DFS requirements during normal operation**

Requirement	Operational Mode		
	Master	Client Without Radar Detection	Client With Radar Detection
<i>DFS Detection Threshold</i>	Yes	Not required	Yes
<i>Channel Closing Transmission Time</i>	Yes	Yes	Yes
<i>Channel Move Time</i>	Yes	Yes	Yes
<i>U-NII Detection Bandwidth</i>	Yes	Not required	Yes

The operational behavior and individual DFS requirements that are associated with these modes are as follows:

**5.1.1 Master Devices**

- a) The *Master Device* will use DFS in order to detect *Radar Waveforms* with received signal strength above the *DFS Detection Threshold* in the 5250 – 5350 MHz and 5470 – 5725 MHz bands. DFS is not required in the 5150 – 5250 MHz or 5725 – 5825 MHz bands.
- b) Before initiating a network on a *Channel*, the *Master Device* will perform a *Channel Availability Check* for a specified time duration (*Channel Availability Check Time*) to ensure that there is no radar system operating on the *Channel*, using DFS described under subsection a) above.
- c) The *Master Device* initiates a U-NII network by transmitting control signals that will enable other U-NII devices to *Associate* with the *Master Device*.
- d) During normal operation, the *Master Device* will monitor the *Channel (In-Service Monitoring)* to ensure that there is no radar system operating on the *Channel*, using DFS described under a).



- e) If the *Master Device* has detected a *Radar Waveform* during *In-Service Monitoring* as described under d), the *Operating Channel* of the U-NII network is no longer an *Available Channel*. The *Master Device* will instruct all associated *Client Device(s)* to stop transmitting on this *Channel* within the *Channel Move Time*. The transmissions during the *Channel Move Time* will be limited to the *Channel Closing Transmission Time*.
- f) Once the *Master Device* has detected a *Radar Waveform* it will not utilize the *Channel* for the duration of the *Non-Occupancy Period*.<sup>2</sup>
- g) If the *Master Device* delegates the *In-Service Monitoring* to a *Client Device*, then the combination will be tested to the requirements described under d) through f) above.

### 5.1.2 Client Devices

- a) A *Client Device* will not transmit before having received appropriate control signals from a *Master Device*.
- b) A *Client Device* will stop all its transmissions whenever instructed by a *Master Device* to which it is associated and will meet the *Channel Move Time* and *Channel Closing Transmission Time* requirements. The *Client Device* will not resume any transmissions until it has again received control signals from a *Master Device*.
- c) If a *Client Device* is performing *In-Service Monitoring* and detects a *Radar Waveform* above the *DFS Detection Threshold*, it will inform the *Master Device*. This is equivalent to the *Master Device* detecting the *Radar Waveform* and d) through f) of section 5.1.1 apply.
- d) Irrespective of *Client Device* or *Master Device* detection the *Channel Move Time* and *Channel Closing Transmission Time* requirements remain the same.

## 5.2 DFS Detection Thresholds

**Table 3** below provides the *DFS Detection Thresholds* for *Master Devices* as well as *Client Devices* incorporating *In-Service Monitoring*.

---

<sup>2</sup> Applies to detection during the Channel Availability Check or In-Service Monitoring.

**Table 3: DFS Detection Thresholds for Master Devices and Client Devices With Radar Detection**

Maximum Transmit Power	Value (See Notes 1, 2, and 3)
EIRP $\geq$ 200 milliwatt	-64 dBm
EIRP < 200 milliwatt and power spectral density < 10 dBm/MHz	-62 dBm
EIRP < 200 milliwatt that do not meet the power spectral density requirement	-64 dBm
<p><b>Note 1:</b> This is the level at the input of the receiver assuming a 0 dBi receive antenna.</p> <p><b>Note 2:</b> Throughout these test procedures an additional 1 dB has been added to the amplitude of the test transmission waveforms to account for variations in measurement equipment. This will ensure that the test signal is at or above the detection threshold level to trigger a DFS response.</p> <p><b>Note 3:</b> EIRP is based on the highest antenna gain. For MIMO devices refer to KDB Publication 662911 D01.</p>	

### 5.3 Response Requirements

**Table 4** provides the response requirements for *Master* and *Client Devices* incorporating DFS.

**Table 4: DFS Response Requirement Values**

Parameter	Value
<i>Non-occupancy period</i>	Minimum 30 minutes
<i>Channel Availability Check Time</i>	60 seconds
<i>Channel Move Time</i>	10 seconds See Note 1.
<i>Channel Closing Transmission Time</i>	200 milliseconds + an aggregate of 60 milliseconds over remaining 10 second period. See Notes 1 and 2.
<i>U-NII Detection Bandwidth</i>	Minimum 100% of the U-NII 99% transmission power bandwidth. See Note 3.
<p><b>Note 1:</b> The instant that the <i>Channel Move Time</i> and the <i>Channel Closing Transmission Time</i> begins is as follows:</p> <ul style="list-style-type: none"> <li>• For the Short Pulse Radar Test Signals this instant is the end of the <i>Burst</i>.</li> <li>• For the Frequency Hopping radar Test Signal, this instant is the end of the last radar <i>Burst</i> generated.</li> <li>• For the Long Pulse Radar Test Signal this instant is the end of the 12 second period defining the <i>Radar Waveform</i>.</li> </ul> <p><b>Note 2:</b> The <i>Channel Closing Transmission Time</i> is comprised of 200 milliseconds starting at the beginning of the <i>Channel Move Time</i> plus any additional intermittent control signals required</p>	

to facilitate a *Channel* move (an aggregate of 60 milliseconds) during the remainder of the 10 second period. The aggregate duration of control signals will not count quiet periods in between transmissions.

**Note 3:** During the *U-NII Detection Bandwidth* detection test, any one of radar types 0 - 4 can be used and for each frequency step the minimum percentage of detection is 90 percent. Measurements are performed with no data traffic. The 99% power bandwidth is measured with 100 kHz resolution bandwidth.

**6. RADAR TEST WAVEFORMS**

This section provides the parameters for required test waveforms, minimum percentage of successful detections, and the minimum number of trials that must be used for determining DFS conformance. Step intervals of 0.1 microsecond for Pulse Width, 1 microsecond for PRI, 1 MHz for chirp width and 1 for the number of pulses will be utilized for the random determination of specific test waveforms.

**6.1 Short Pulse Radar Test Waveforms**

**Table 5 – Short Pulse Radar Test Waveforms**

Radar Type	Pulse Width (μsec)	PRI (μsec)	Number of Pulses	Minimum Percentage of Successful Detection	Minimum Number of Trials
0	1	1428	18	See Note 1	See Note 1
1	1	Test A: 15 unique PRI values randomly selected from the list of 23 PRI values in Table 5a	Roundup $\left\{ \begin{matrix} \left( \frac{1}{360} \right) \cdot \\ \left( \frac{19 \cdot 10^6}{PRI_{\mu sec}} \right) \end{matrix} \right\}$	60%	30
		Test B: 15 unique PRI values randomly selected within the range of 518-3066 μsec, with a minimum increment of 1 μsec, excluding PRI values selected in Test A			
2	1-5	150-230	23-29	60%	30
3	6-10	200-500	16-18	60%	30
4	11-20	200-500	12-16	60%	30
Aggregate (Radar Types 1-4)				80%	120

**Note 1:** Short Pulse Radar Type 0 shall only be used for the channel availability and detection bandwidth tests. It should be noted that any of the radar test waveforms 0 – 4 can be used for the channel availability and detection bandwidth tests.

A minimum of 30 unique waveforms are required for each of the Short Pulse Radar Types 2 through 4. If more than 30 waveforms are used for Short Pulse Radar Types 2 through 4, then each additional waveform must also be unique and not repeated from the previous waveforms. If more than 30 waveforms are used for Short Pulse Radar Type 1, then each additional waveform is generated with Test B and must also be unique and not repeated from the previous waveforms in Tests A or B.

For example if in Short Pulse Radar Type 1 Test B a PRI of 3066 usec is selected, the number of pulses

would be  $\text{Roundup}\left\{\left(\frac{1}{360}\right) \cdot \left(\frac{19 \cdot 10^6}{3066}\right)\right\} = \text{Roundup}\{17.2\} = 18.$

**Table 5a - Pulse Repetition Intervals Values for Test A**

<b>Pulse Repetition Frequency Number</b>	<b>Pulse Repetition Frequency (Pulses Per Second)</b>	<b>Pulse Repetition Interval (Microseconds)</b>
1	1930.5	518
2	1858.7	538
3	1792.1	558
4	1730.1	578
5	1672.2	598
6	1618.1	618
7	1567.4	638
8	1519.8	658
9	1474.9	678
10	1432.7	698
11	1392.8	718
12	1355	738
13	1319.3	758
14	1285.3	778
15	1253.1	798
16	1222.5	818
17	1193.3	838
18	1165.6	858
19	1139	878
20	1113.6	898
21	1089.3	918
22	1066.1	938
23	326.2	3066

The aggregate is the average of the percentage of successful detections of Short Pulse Radar Types 1-4. For example, the following table indicates how to compute the aggregate of percentage of successful detections.

Radar Type	Number of Trials	Number of Successful Detections	Minimum Percentage of Successful Detection
1	35	29	82.9%
2	30	18	60%
3	30	27	90%
4	50	44	88%
Aggregate $(82.9\% + 60\% + 90\% + 88\%)/4 = 80.2\%$			

## 6.2 Long Pulse Radar Test Waveform

**Table 6 – Long Pulse Radar Test Waveform**

Radar Type	Pulse Width (μsec)	Chirp Width (MHz)	PRI (μsec)	Number of Pulses per <i>Burst</i>	Number of <i>Bursts</i>	Minimum Percentage of Successful Detection	Minimum Number of Trials
5	50-100	5-20	1000-2000	1-3	8-20	80%	30

The parameters for this waveform are randomly chosen. Thirty unique waveforms are required for the Long Pulse Radar Type waveforms. If more than 30 waveforms are used for the Long Pulse Radar Type waveforms, then each additional waveform must also be unique and not repeated from the previous waveforms.

Each waveform is defined as follows:

- 1) The transmission period for the Long Pulse Radar test signal is 12 seconds.
- 2) There are a total of 8 to 20 *Bursts* in the 12 second period, with the number of *Bursts* being randomly chosen. This number is *Burst\_Count*.
- 3) Each *Burst* consists of 1 to 3 pulses, with the number of pulses being randomly chosen. Each *Burst* within the 12 second sequence may have a different number of pulses.
- 4) The pulse width is between 50 and 100 microseconds, with the pulse width being randomly chosen. Each pulse within a *Burst* will have the same pulse width. Pulses in different *Bursts* may have different pulse widths.
- 5) Each pulse has a linear frequency modulated chirp between 5 and 20 MHz, with the chirp width being randomly chosen. Each pulse within a *Burst* will have the same chirp width. Pulses in different *Bursts* may have different chirp widths. The chirp is centered on the pulse. For example, with a radar frequency of 5300 MHz and a 20 MHz chirped signal, the chirp starts at 5290 MHz and ends at 5310 MHz.
- 6) If more than one pulse is present in a *Burst*, the time between the pulses will be between 1000 and 2000 microseconds, with the time being randomly chosen. If three pulses are present in a *Burst*, the random time interval between the first and second pulses is chosen independently of the random time interval between the second and third pulses.

- 7) The 12 second transmission period is divided into even intervals. The number of intervals is equal to *Burst\_Count*. Each interval is of length  $(12,000,000 / \textit{Burst\_Count})$  microseconds. Each interval contains one *Burst*. The start time for the *Burst*, relative to the beginning of the interval, is between 1 and  $[(12,000,000 / \textit{Burst\_Count}) - (\textit{Total Burst Length}) + (\textit{One Random PRI Interval})]$  microseconds, with the start time being randomly chosen. The step interval for the start time is 1 microsecond. The start time for each *Burst* is chosen randomly.

**A representative example of a Long Pulse Radar Type waveform:**

- 1) The total test waveform length is 12 seconds.
- 2) Eight (8) *Bursts* are randomly generated for the *Burst\_Count*.
- 3) *Burst* 1 has 2 randomly generated pulses.
- 4) The pulse width (for both pulses) is randomly selected to be 75 microseconds.
- 5) The PRI is randomly selected to be at 1213 microseconds.
- 6) *Bursts* 2 through 8 are generated using steps 3 – 5.
- 7) Each *Burst* is contained in even intervals of 1,500,000 microseconds. The starting location for Pulse 1, *Burst* 1 is randomly generated (1 to 1,500,000 minus the total *Burst* 1 length + 1 random PRI interval) at the 325,001 microsecond step. *Bursts* 2 through 8 randomly fall in successive 1,500,000 microsecond intervals (i.e. *Burst* 2 falls in the 1,500,001 – 3,000,000 microsecond range).

**Figure 1** provides a graphical representation of the Long Pulse Radar Test Waveform.

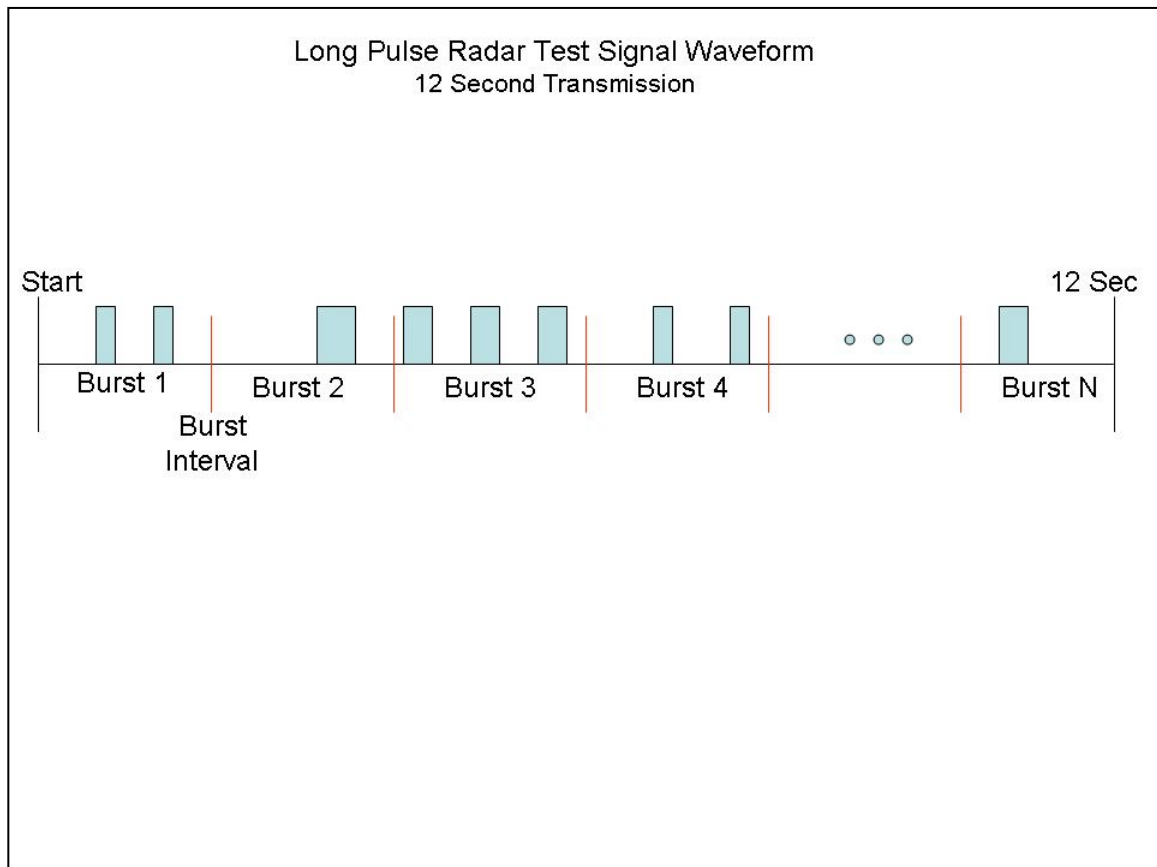

**Figure 1: Graphical Representation of a Long Pulse Radar Type Waveform**

**6.3 Frequency Hopping Radar Test Waveform**

**Table 7 – Frequency Hopping Radar Test Waveform**

Radar Type	Pulse Width (µsec)	PRI (µsec)	Pulses per Hop	Hopping Rate (kHz)	Hopping Sequence Length (msec)	Minimum Percentage of Successful Detection	Minimum Number of Trials
6	1	333	9	0.333	300	70%	30

For the Frequency Hopping Radar Type, the same *Burst* parameters are used for each waveform. The hopping sequence is different for each waveform and a 100-length segment is selected from the hopping sequence defined by the following algorithm:<sup>3</sup>

The first frequency in a hopping sequence is selected randomly from the group of 475 integer frequencies from 5250 – 5724 MHz. Next, the frequency that was just chosen is removed from the group and a frequency is randomly selected from the remaining 474 frequencies in the group. This process continues until all 475 frequencies are chosen for the set. For selection of a random frequency, the frequencies remaining within the group are always treated as equally likely.

**7. TEST PROCEDURES**

**7.1 Test Protocol**

For a *Master Device*, the DFS conformance requirements specified in Section 7.8 will be verified utilizing the Short Pulse Radar Types defined in **Table 5**. Additionally, the *Channel Move Time* and *Channel Closing Transmission Time* requirements specified in Section 7.8 will be verified utilizing the Long Pulse Radar Type defined in **Table 6**. The statistical performance check specified in Section 7.8 will be verified utilizing all Radar Types (1-6).

For a *Client Device* without DFS, the *Channel Move Time* and *Channel Closing Transmission Time* requirements specified in Section 7.8 will be verified with one Short Pulse Radar Type defined in **Table 5**.

For testing a *Client Device* with *In-Service Monitoring*, two configurations must be tested.

- 1) The *Client Device* detects the *Radar Waveform*. The *Channel Move Time* and *Channel Closing Transmission Time* requirements specified in Section 7.8 will be verified utilizing Short Pulse Radar Types defined in **Table 5** and the Long Pulse Radar Type defined in **Table 6**. The statistical performance check specified in Section 7.8 will be verified utilizing all Radar Types (1-6). During this test, it must be ensured that the *Client Device* is responding independently based on the *Client Device*'s self-detection rather than responding to detection by the *Master Device*. The signal level of the *Radar Waveform* as received by the *Client Device* must be set in accordance with the *DFS Detection Threshold* specified by the DFS technical requirements (**Table 3**).
- 2) The *Master Device* detects the *Radar Waveform*. The *Channel Move Time* and *Channel Closing Transmission Time* requirements specified in Section 7.8 will be verified utilizing Short Pulse Radar Type defined in **Table 5**. During this test, it must be ensured that the *Client Device* is responding to detection by the *Master Device* rather than self-detection by the *Client Device*.

<sup>3</sup> If a segment does not contain at least 1 frequency within the *U-NII Detection Bandwidth* of the UUT, then that segment is not used.



For all tests of *Client Devices* (with or without *In-Service Monitoring*), the *Master Device* to which the *Client Device* is associated must meet the DFS conformance requirements.

Some of the tests may be performed more readily if a test mode for a *Master Device* (or *Client Device* with *In-Service Monitoring*) is provided that overrides the *Channel* selection to allow a specific *Channel* to be set for startup (*Channel Availability Check*). In this mode it is preferable that the *Master Device* will continue normal operation upon starting (i.e. perform *Channel Availability Check* on the chosen *Channel* and begin normal operation if no *Radar Waveform* is detected – or respond normally if a *Radar Waveform* is detected during the *Channel Availability Check* or *In-Service Monitoring* on the chosen *Channel*). However, this mode of operation is not required to successfully complete the testing.

Other tests may be performed more readily if a test mode for a *Master Device* (or a *Client Device* with *In-Service Monitoring*) is provided that overrides the *Channel* move mechanism and simply provides a display that a *Radar Waveform* was detected. In this mode it is preferable that the UUT will continue operation on the same *Channel* upon detecting a *Radar Waveform*. However, this mode of operation is not required to successfully complete the testing.

Once a UUT is powered on, it will not start its normal operating functions immediately, as it will have to finish its power-up cycle first ( $T_{\text{power\_up}}$ ). As such, the UUT, as well as any other device used in the setup, may be equipped with a feature that indicates its status during the testing, including, for example, power-up mode, normal operation mode, *Channel Availability Check* status and radar detection events.

The test transmission will always be from the *Master Device* to the *Client Device*.

## 7.2 Conducted Tests

The sections below contain block diagrams that focus on the *Radar Waveform* injection path for each of the different conducted setups to be used. Each setup consists of a signal generator, analyzer (spectrum analyzer or vector signal analyzer), *Master Device*, *Client Device*, plus power combiner/splitters and attenuators. The *Client Device* is set up to *Associate* with the *Master Device*. The designation of the UUT (*Master Device* or *Client Device*) and the device into which the *Radar Waveform* is injected varies among the setups.

Other topologies may be used provided that: (1) the radar and UUT signals can be discriminated from each other on the analyzer and (2) the radar *DFS Detection Threshold* level at the UUT is stable.

To address point (1), for typical UUT power levels and typical minimum antenna gains, the topologies shown will result in the following relative amplitudes of each signal as displayed on the analyzer: the *Radar Waveform* level is the highest, the signal from the UUT is the next highest, while the signal from the device that is associated with the UUT is the lowest. Attenuator values may need to be adjusted for particular configurations.

To address point (2), the isolation characteristic between ports 1 and 2 of a power combiner/splitter are extremely sensitive to the impedance presented to the common port, while the insertion loss characteristic between the common port and (port 1, for example) are relatively insensitive to the impedance presented to (port 2, in this example). Thus, the isolation between ports 1 and 2 should never be part of the path that establishes the radar *DFS Detection Threshold*. The 10 dB attenuator after the signal generator is specified as a precaution; since many of the radar test waveforms will require typical signal generators to operate with their ALC turned off, the source match will generally be degraded from the closed loop specifications.

**7.2.1 Setup for Master with injection at the Master**

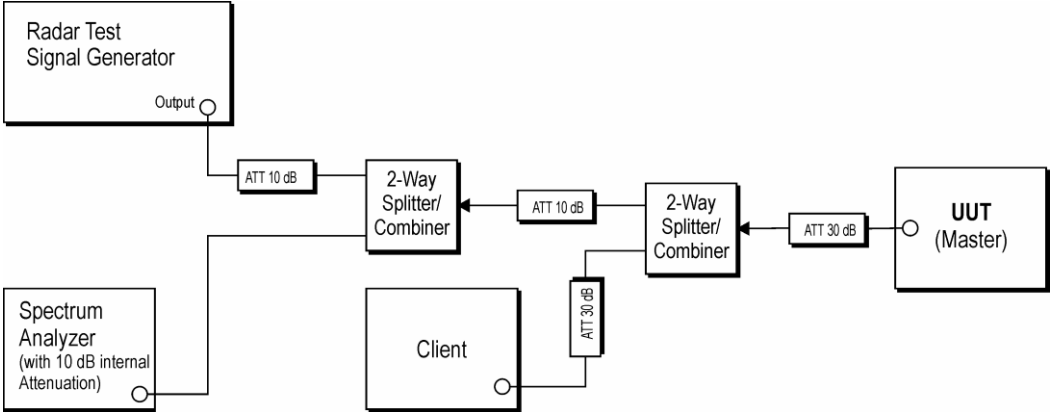

*Figure 2: Example Conducted Setup where UUT is a Master and Radar Test Waveforms are injected into the Master*

**7.2.2 Setup for Client with injection at the Master**

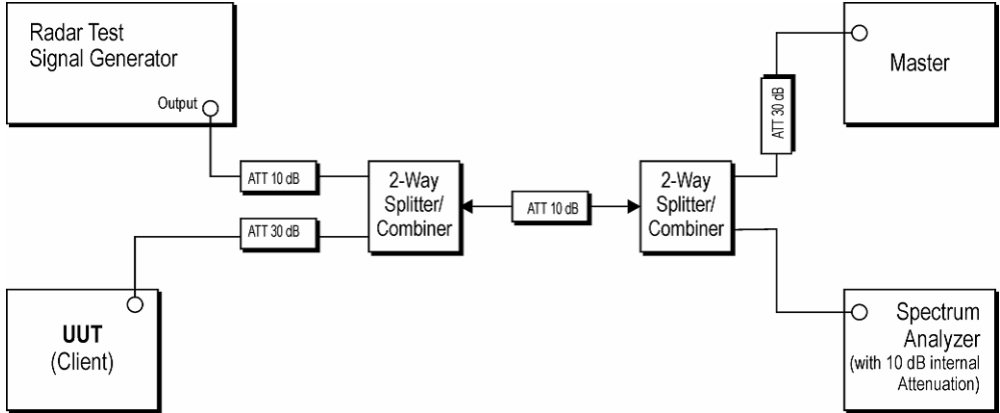

*Figure 3: Example Conducted Setup where UUT is a Client and Radar Test Waveforms are injected into the Master*

### 7.2.3 Setup for Client with injection at the Client

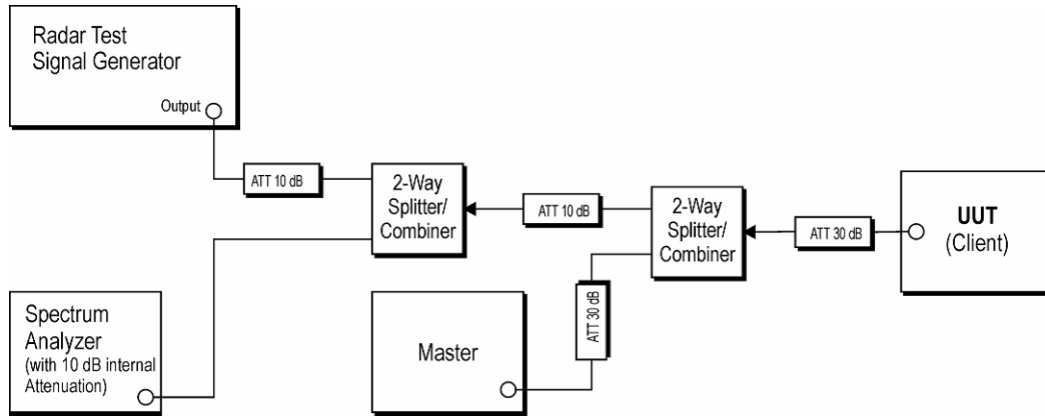

Figure 4: Example Conducted Setup where UUT is a Client and Radar Test Waveforms are injected into the Client

## 7.3 Radiated Tests

The subsections below contain simplified block diagrams that illustrate the *Radar Waveform* injection path for each of the different radiated setups to be used. The basic setup is identical for all cases.

### 7.3.1 Master with injection at the Master

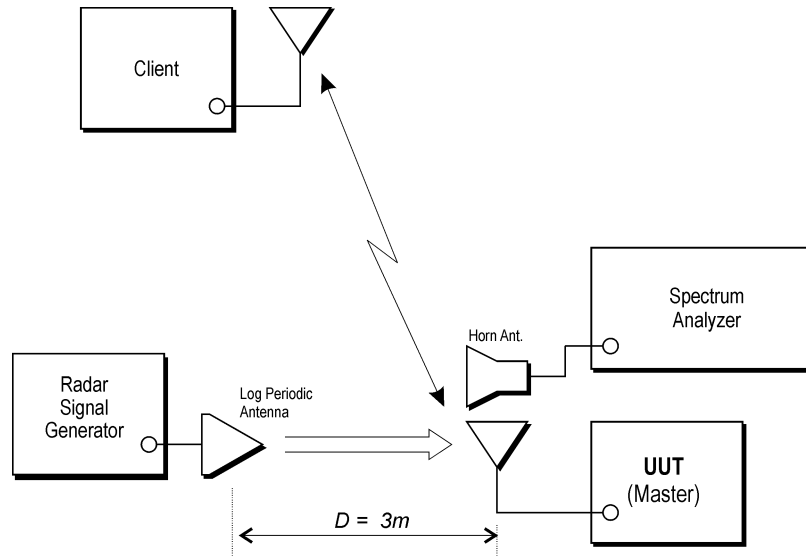
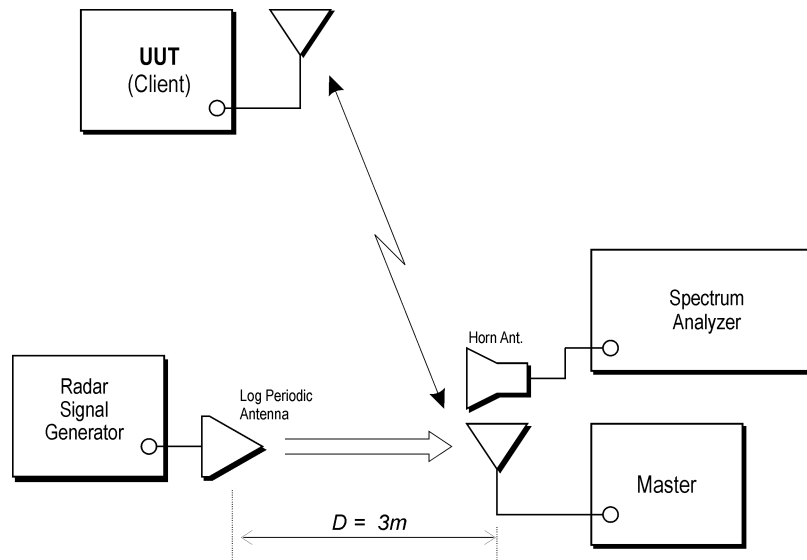

Figure 5: Example Radiated Setup where UUT is a Master and Radar Test Waveforms are injected into the Master

**7.3.2 Client with injection at the Master**



*Figure 6: Example Radiated Setup where UUT is a Client and Radar Test Waveforms are injected into the Master*

**7.3.3 Client with injection at the Client**

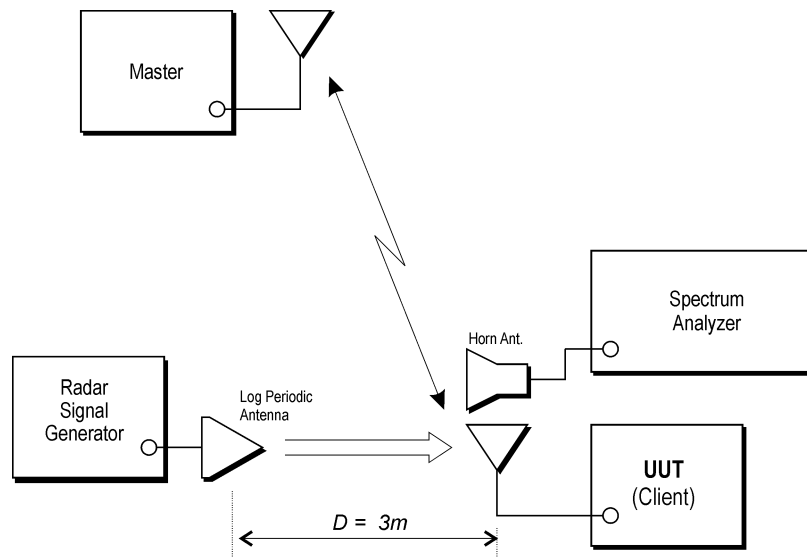

*Figure 7: Example Radiated Setup where UUT is a Client and radar Test Waveforms are injected into the Client*

**7.4 Test Signal Generation**

A complete test system consists of two subsystems: (1) the *Radar Waveform* generating subsystem and (2) the DFS monitoring subsystem. Method #1 and Method #2 subsystems are described for the *Radar Waveform* generating subsystem and the DFS monitoring subsystems. These two subsystems are independent such that the Method #1 subsystem for one function can be used with the Method #2 subsystem for the other function.

The Method #1 subsystems schematics and a parts list are available to those who are interested in replicating the custom hardware devices. The custom software and data files that control this subsystem will be made available to those who are interested.<sup>4</sup>

The Method #2 subsystems used to generate simulated frequency hopping waveforms will be made available to those who are interested.<sup>5</sup>

Other instrument configurations may also be used. However, any deviations from the subsystems described here must be submitted to the FCC for evaluation.

### 7.4.1 Radar Waveform Generating Subsystems

Computer control is not necessary to generate the Short Pulse *Radar Waveforms*. However, the Long Pulse *Radar Waveform* and Frequency Hopping *Radar Waveforms* by their nature require computer control. Both of the Frequency Hopping *Radar Waveform* generating subsystems can also generate the required Short Pulse *Radar Waveforms*.

A manually operated Short Pulse *Radar Waveform* generating subsystem is described, followed by descriptions of the computer controlled Frequency Hopping *Radar Waveform* generating subsystems.

#### 7.4.1.1 Short Pulse Radar Waveform Generating Subsystem

**Figure 8** shows the setup for the Short Pulse *Radar Waveform* generating subsystem.

The pulse generator is adjusted to the shortest rise and fall times. The pulse width, PRI, and number of pulses per *Burst* are set according to the Short Pulse *Radar Waveforms* (**Table 5**). The pulse generator is triggered manually. The trigger output from the pulse generator can also be connected to the DFS monitoring subsystem as required to synchronize the two subsystems.

The Signal Generator is set to the *Channel* center frequency and pulse modulation mode. The amplitude is adjusted to achieve the specified *DFS Detection Threshold* (**Table 3**).

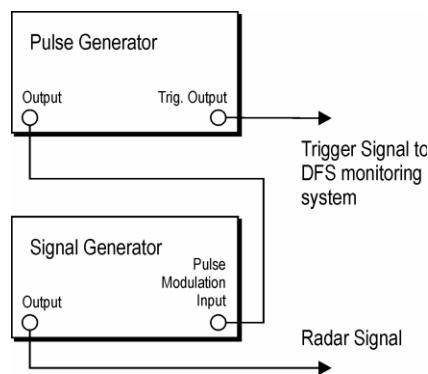

**Figure 8: Short Pulse Radar Waveform Generating Subsystem**

<sup>4</sup> A link will be provided in the final KDB publication for the most recent radar pulse generation software.

<sup>5</sup> A link will be provided in the final KDB publication for the most recent frequency hopping software.

#### **7.4.1.2 Method #1 Radar Waveform Generating Subsystems**

With the exception of the Frequency Doubler and the DFS Test Box, the test and measurement system uses off-the-shelf components with vendor-supplied software and customized software. **Figures 9a-9d** shows the example setup for the Method #1 *Radar Waveform* Generating Subsystems.

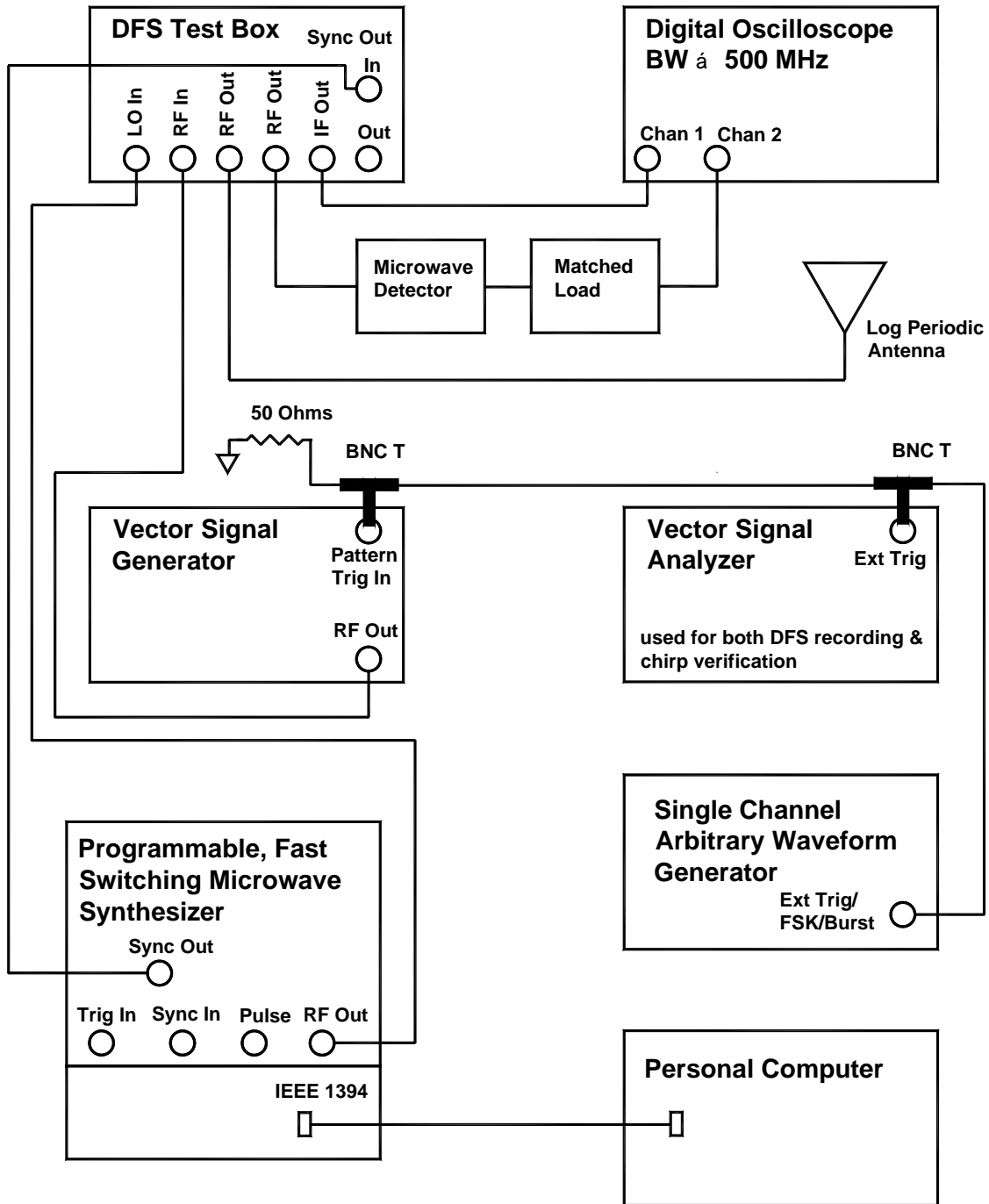

Figure 9a: Example Short and Long Pulse Radar Waveform Generator



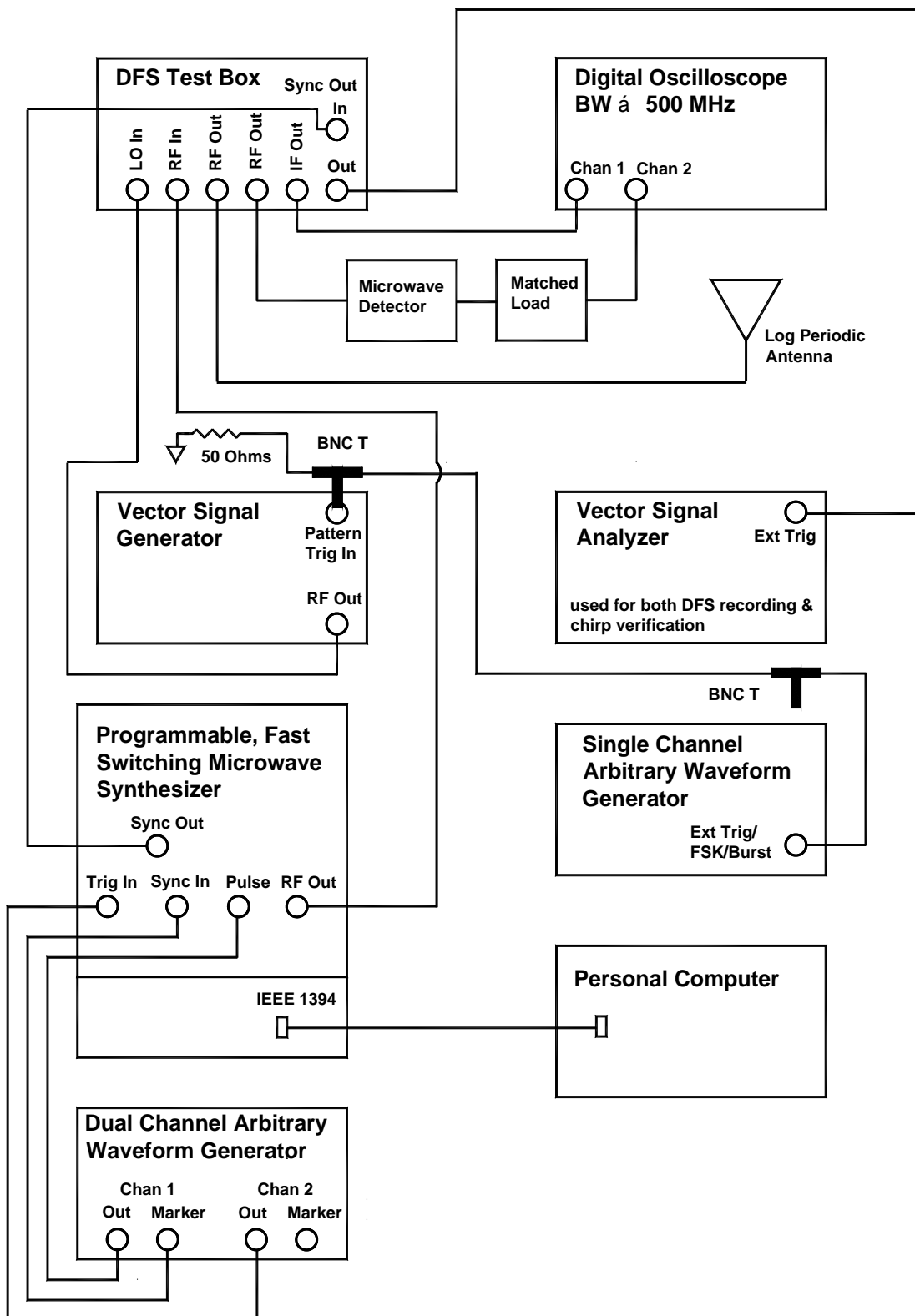

Figure 9b: Example Frequency Hopping Radar Waveform Generator

The first step in generating the Frequency Hopping *Radar Waveform* is accomplished by entering 274 sets of hopping sequences of the randomized 475 hop frequencies into a frequency list stored in memory in the fast-switching microwave synthesizer.

Generation of the Frequency Hopping *Radar Waveform* proceeds as follows: The center frequency of the microwave synthesizer is set according to the frequency list in the synthesizer's memory. The microwave synthesizer is set up to run for 10 seconds at a time (one *Burst* period).<sup>6</sup> During the ten-second-burst period, every 3 milliseconds the microwave synthesizer switches (hops) to the next frequency in the frequency list. The microwave synthesizer's center frequency is pulse modulated by a pulse train that consists of a *Burst* of 900 pulses (each with a 1 microsecond pulse width) that occurs at the beginning of the ten-second-burst period. The PRI of the *Burst* is 333 microsecond. Therefore, the hopping sequence length is 300 milliseconds and there are 9 pulses per frequency hop.

Because the pulses occur within the first 300 millisecond of the ten-second-burst period, only the first 100 frequencies out of a given set of 475 randomized frequencies are actually transmitted. Therefore, it is possible for none of the transmitted frequencies during a ten-second-burst period to fall within the receiver bandwidth of the U-NII device being tested. Whenever this occurs the particular ten-second-burst period will not be included in the performance of the U-NII device.

---

<sup>6</sup> Up to 40 ten-second-burst periods may be run with unique random frequency hop sets. These 40 ten-second-burst periods may be transmitted one at a time or any number of them may be transmitted contiguously. After all 40 ten-second-burst periods have been transmitted, the test needs to be restarted at the beginning of either the current frequency list or a newly loaded, different frequency list.

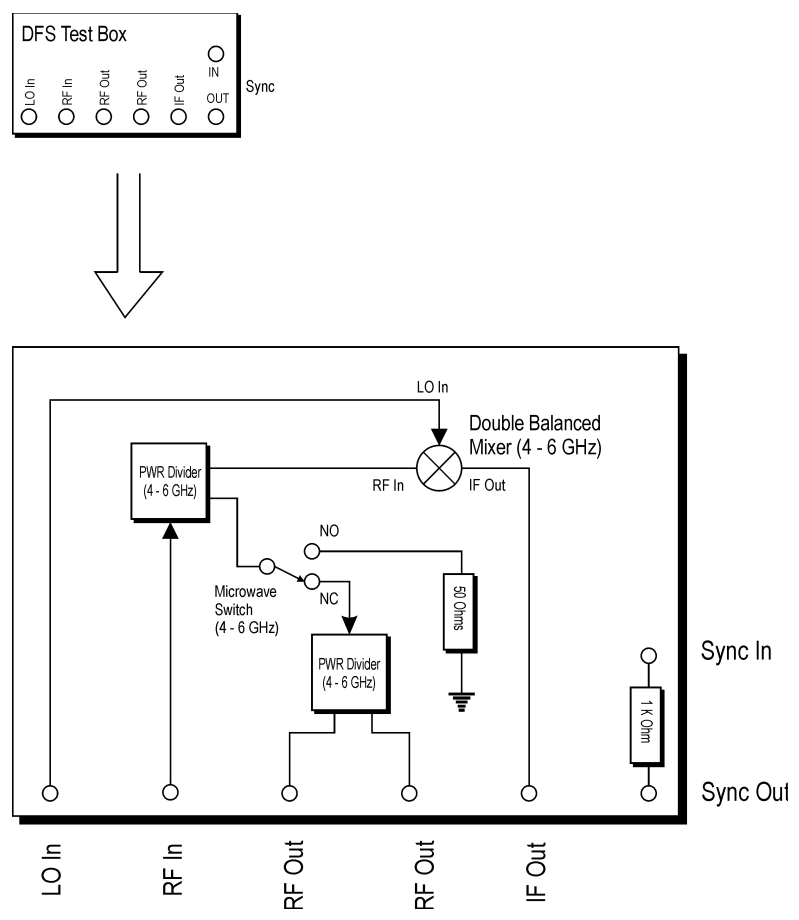

Figure 9c: Example DFS Test Box

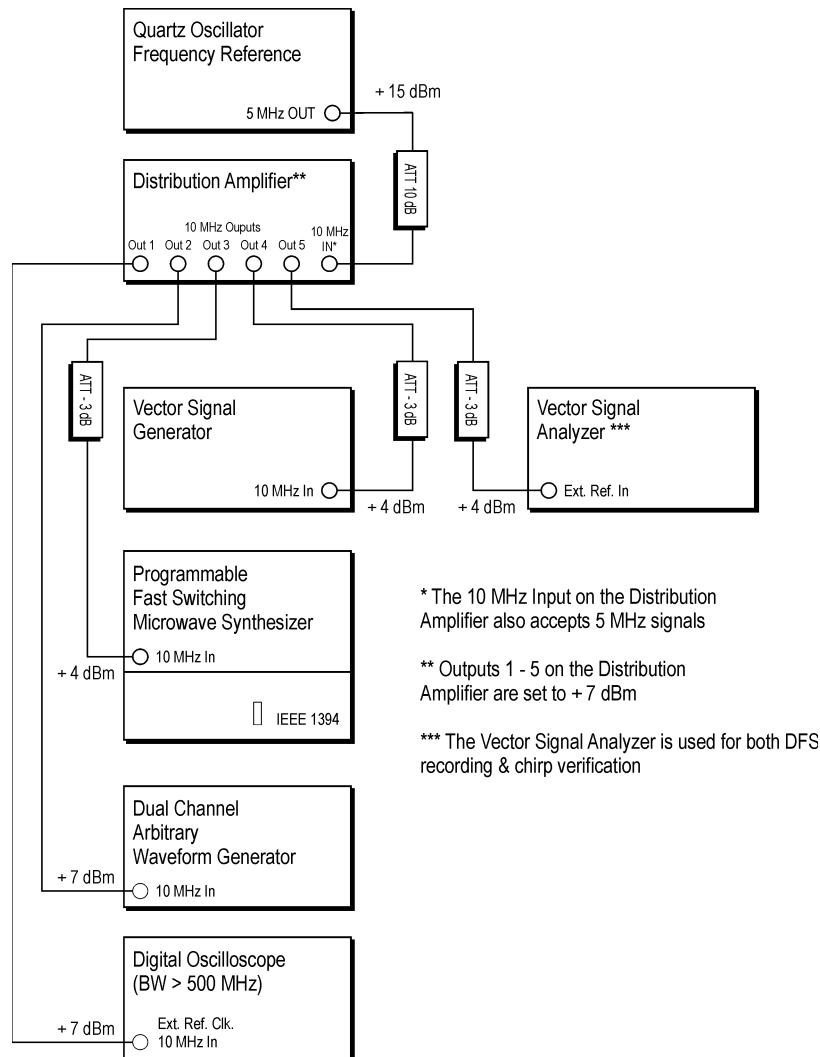

Figure 9d: Example Reference Oscillator Distribution

**Quartz Oscillator Frequency Reference**

The quartz oscillator provides a 5 MHz frequency reference signal that is distributed to the signal generators and measurement equipment via the distribution amplifier.

**Distribution Amplifier**

The distribution amplifier takes the 5 MHz frequency reference signal from the quartz oscillator, doubles it and distributes the resulting 10 MHz frequency reference signal to the critical signal generators and measurement equipment. This ensures synchronization of the signal generators and measurement equipment.

**Digital Oscilloscope**

The digital oscilloscope is used to examine the down-converted or detected radar transmissions in a full 500 MHz bandwidth. This is used to verify that the radar transmissions comply with the parameters as specified by the radar test waveforms.

**Dual Channel Arbitrary Waveform Generator**

The dual channel arbitrary waveform generator (AWG) is used when the system is configured to transmit frequency-hopping waveforms. The dual channel AWG produces two synchronized pulse trains that provide signals to control the fast-switching microwave synthesizer. One pulse train controls the microwave synthesizer switches (hops) to the next frequency in the frequency list. The other pulse train pulse modulates the RF output of the microwave synthesizer.

**Microwave Detector and Matched Load**

The microwave detector is used to monitor the envelope of the RF radar transmissions on the digital oscilloscope.

**Radar Transmit Antenna**

For radiated tests a log periodic antenna or equivalent directional antenna is used to transmit the *Radar Waveforms* to the DFS device during testing of the U-NII device.

**Single Channel Arbitrary Waveform Generator**

The single channel AWG is used when the *Radar Waveform* generator system is configured to transmit the Short Pulse Radar Type 0-5 waveforms. The single channel AWG is used to generate a trigger signal to begin transmission of the *Radar Waveform* and begin recording U-NII transmissions on the vector signal analyzer (VSA).

**DFS Test Box**

The DFS Test Box is constructed using off-the-shelf components. The DFS Test Box facilitates signal routing and monitoring for the radar transmissions. The radar transmissions are routed to the RF input of the DFS Test Box. The IF output provides a down-converted version of the RF radar transmissions. Two ports are available for RF output. One is connected to the log periodic antenna for radiated testing of the U-NII devices or directly to the UUT for conducted testing. The other RF output is connected to a microwave detector to display the envelope of the RF radar transmissions. Both the IF output and the detector output can be observed on the digital oscilloscope in a full 500 MHz bandwidth. This allows observation of the frequency-hopping signal that hops across 475 MHz. Both the IF output and the detector output can be used to verify *Radar Waveform* characteristics. The detector output can also be used to verify that an RF output signal is present.

**Vector Signal Generator**

When the *Radar Waveform* generator system is configured to transmit the frequency hopping signal, the vector signal generator (VSG) is used as a 5225 MHz continuous-wave (CW) signal source for the local oscillator (LO) input to the DFS Test Box. When the *Radar Waveform* generator system is configured to transmit radar types 0-5 waveforms, the VSG is used to transmit the Short Pulse Radar Types 0-5 waveforms. The Short Pulse Radar Types 0-5 waveforms are created using custom software. After the waveforms are created they are loaded into the VSG.

**Personal Computer**

The personal computer is used to generate and load the frequency-hopping list into and properly set up the fast-switching microwave synthesizer.

### Fast-Switching Microwave Synthesizer

When the *Radar Waveform* generator system is configured to transmit the Short Pulse Radar Types 0-5 waveforms, the microwave synthesizer is used as a 5225 MHz CW signal source for the LO input to the DFS Test Box. When the *Radar Waveform* generator system is configured to transmit the frequency-hopping signal, the microwave synthesizer is used to transmit the frequency-hopping signal. Custom software is used to generate and load the hopping frequency list into and properly set up the fast-switching microwave synthesizer. A pulse train generated by the dual channel AWG controls when the microwave synthesizer switches (hops) to the next frequency in the frequency list. Another pulse train from the dual channel AWG pulse modulates the RF output of the microwave synthesizer to complete the generation of the frequency-hopping signal.

### Vector Signal Analyzer

The VSA is used for two distinct purposes. One use is to verify the chirped radar transmissions of the Long Pulse Radar Type 5 waveforms. The FM demodulation capability is used to verify the chirp frequency range. The other use of the VSA is to provide 12 and 24 second recordings of the U-NII device transmissions, with fine-time resolution, during DFS testing. When Long Pulse Radar Type 5 waveforms are transmitted, the 24-second recordings (with a time between samples of approximately 675 nanoseconds) are taken; 12-second recordings (with a time between samples of approximately 390 nanoseconds) are taken when all other *Radar Waveforms* are transmitted.

The VSA receives a trigger signal from the *Radar Waveform* generator system to initiate a recording. When the *Radar Waveform* generator system is configured to transmit the Radar Types 0-5 waveforms, the single-channel AWG provides the trigger signal. When the *Radar Waveform* generator system is configured to transmit the frequency hopping signal, the microwave synthesizer generates the trigger signal when the frequency hopping radar transmission first falls within the *U-NII Detection Bandwidth*.

#### 7.4.1.3 Method #2 Simulated Frequency Hopping Radar Waveform Generating Subsystem

The simulated frequency hopping signal generator system uses the hardware that is used to manually generate Short Pulse *Radar Waveforms* shown in **Figure 8**, with the addition of a control computer and a *Burst* generator to create the hopping trigger pulse pattern. The simulated signal generation approach produces both time-domain and frequency-domain simulations of an actual frequency hopping signal. The hardware configuration for an example Frequency Hopping *Radar Waveform* generator is shown in **Figure 10**.

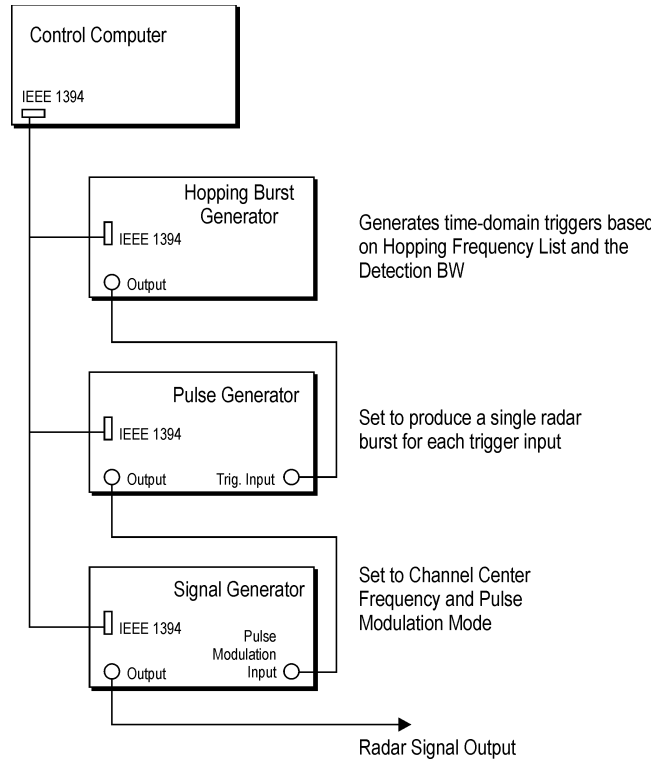

**Figure 10: Example Simulated Frequency Hopping Radar Generator System**

### Conceptual Description of Simulated Frequency Hopping Generator

**Time-domain simulation:** The simulated hopping system generates the same number of hops, using identical pulse parameters, at the identical timing compared to the actual hopping waveform, using a fixed frequency within the *U-NII Detection Bandwidth*. Thus the detectable RF energy received by the UUT is identical in both instances.

**Frequency-domain simulation:** Multiple trials are made, each at a different fixed frequency. The frequencies selected for each trial lie within the *U-NII Detection Bandwidth*. Thus the UUT receives RF energy throughout the *U-NII Detection Bandwidth*.

**Figure 11** and **Figure 12** below show the comparison between an example frequency hopping waveform and the corresponding simulated hopping waveform. The horizontal axis is time and the vertical axis is frequency (although the figures depict 3 pulses per hop, the actual Frequency Hopping Radar Type 6 waveform contains 9 pulses per hop).

Referring to the actual hopping signal, the hops that are outside the *U-NII Detection Bandwidth* are shown as three dots in **Figure 11** and **Figure 12** and the hops that are within the *U-NII Detection Bandwidth* are shown as three lines. The center of the lines indicates the frequency of the hop. Note that three hops fall within the *U-NII Detection Bandwidth*.

Referring to the simulated hopping signal, the hops that are generated are shown as three lines. Note that three hops are generated, and each hop is at the same frequency.



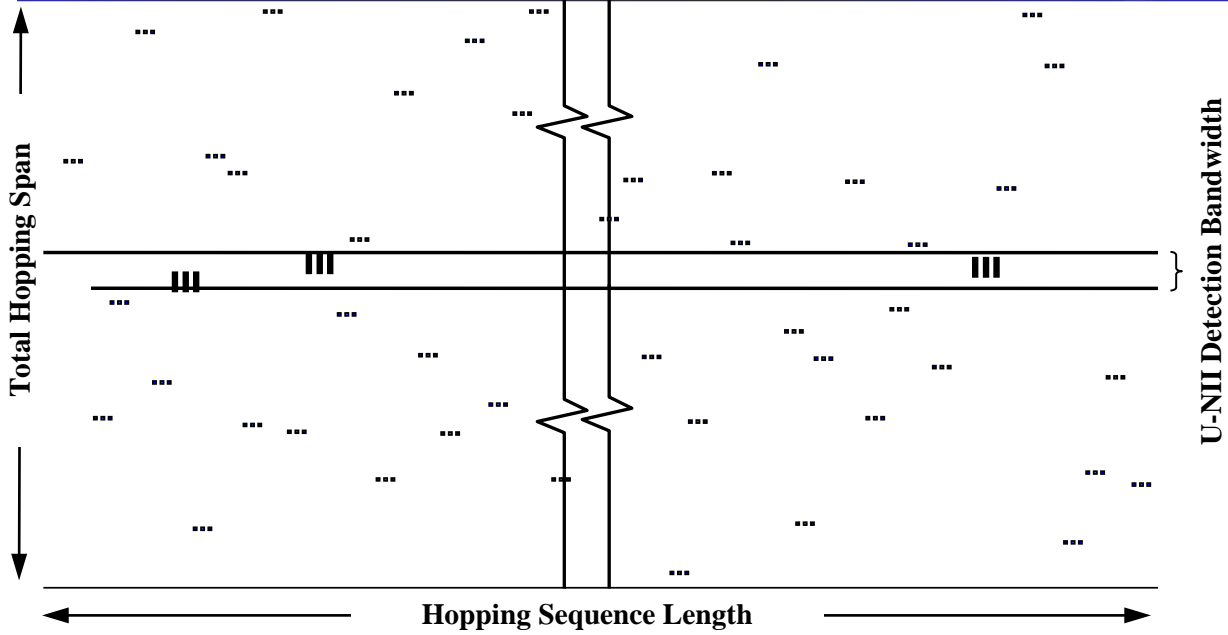

Figure 11: Frequency Hopping Sequence

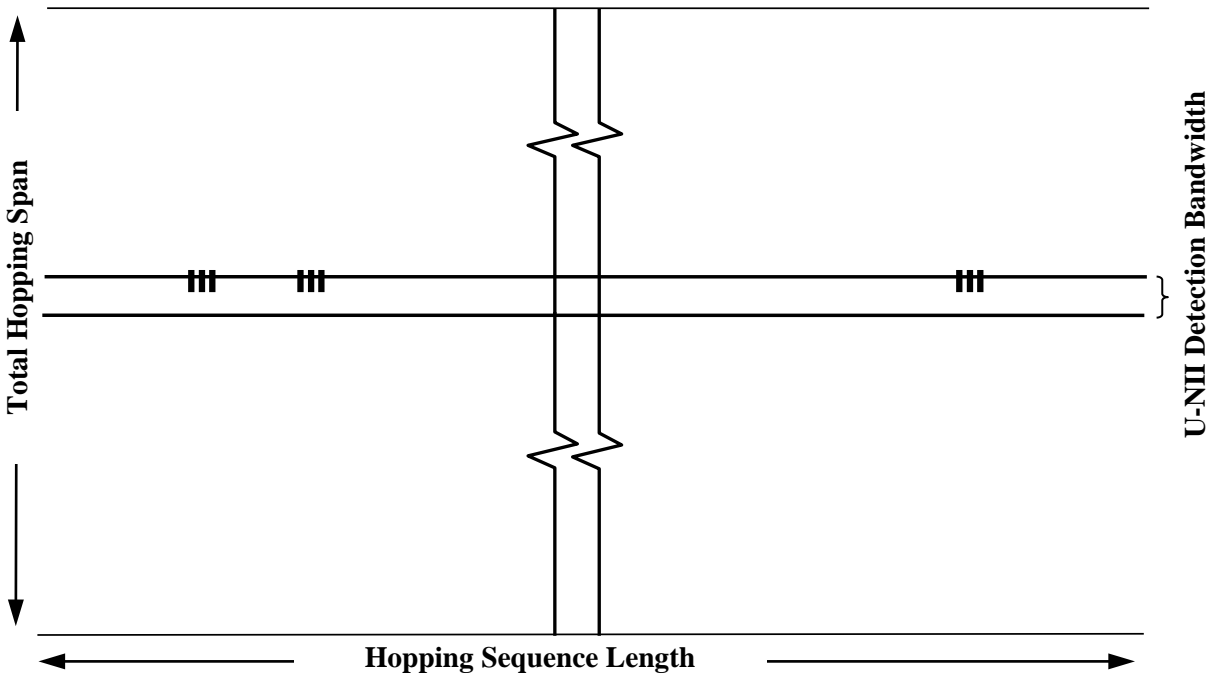

Figure 12: Time Domain Simulation of a Frequency Hopping Sequence

The frequency hopping *Burst* generator is a programmable pulse generator that is used to provide a trigger to generate the *Burst* pattern trigger pulses and the monitoring system.

The pulse generator is configured to generate a single *Burst* of pulses (refer to **Table 7** for the frequency hopping waveform parameters) whenever triggered by the hopping *Burst* generator and is used as the modulation input for the RF signal generator, set to pulse modulation.

### 7.5 Setting the Test Signal Level

The radar test signal level is set at the *Master Device*, or the *Client Device* with *In-Service Monitoring*, as appropriate for the particular test. This device is known as the Radar Detection Device (RDD). The RDD consists of the applicable device and the device antenna assembly that has the lowest antenna assembly gain of all available antenna assemblies. Depending on the UUT, the following configurations exist:

- When the *Master Device* is the UUT, the *Master Device* is the RDD.
- When a *Client Device* without Radar Detection is the UUT, the *Master Device* is the RDD.
- When a *Client Device* with Radar Detection is the UUT, and is tested for response to the *Master Device* detections, the *Master Device* is the RDD.
- When a *Client Device* with Radar Detection is the UUT, and is tested for independent response to detections by the *Client Device*, the *Client Device* is the RDD.

A spectrum analyzer is used to establish the test signal level for each radar type. During this process, there are no transmissions by either the *Master Device* or *Client Device*. The spectrum analyzer is switched to the zero span (time domain) mode at the frequency of the *Radar Waveform* generator. The peak detector function of the spectrum analyzer is utilized. The spectrum analyzer resolution bandwidth (RBW) and video bandwidth (VBW) are set to at least 3 MHz.

The signal generator amplitude and/or step attenuators are set so that the power level measured at the spectrum analyzer is equal to the *DFS Detection Threshold* that is required for the tests. The signal generator and attenuator settings are recorded for use during the test.

Data demonstrating that the test signal level is correctly set for each radar type (0-6) will be recorded and reported.

### 7.6 DFS Monitoring

The DFS monitoring subsystem shown in **Figure 13** is used to verify that the UUT has vacated the *Channel* in the specified time (*Channel Closing Transmission Time* and *Channel Move Time*) and does not transmit on a *Channel* for 30 minutes after the detection and *Channel* move (*Non-Occupancy Period*). It is also used to monitor UUT transmissions upon start-up (*Channel Availability Check Time*).

#### 7.6.1 Method #1

The test setup of the Method #1 DFS monitoring subsystem is shown in **Figure 13**. This subsystem consists of two major functional blocks. One measures RF transmissions for a time period of 12 or 24 seconds and the other measures RF transmissions for a time period of 30 minutes.

The 12 and 24 -second measurement is made with a VSA controlled by a computer. A log-periodic antenna, or equivalent directional antenna, connected to the VSA is used to receive the UUT transmissions. Upon receiving a trigger signal from the signal generator system (AWG from the Method

#1 system and Pulse Generator from the Method #2 system), the VSA will digitize the UUT transmissions for 12 or 24 seconds and stored. The stored data are time tagged and the UUT transmissions can be reviewed in voltage vs. time format using the software in the computer controlling the VSA or in a suitable computer program to verify that the UUT complies with the limits.

The 30 minute measuring time is made with a spectrum analyzer connected to an omni antenna. Since the power of the UUT transmissions are well above the noise floor of the analyzer, a preamplifier and tracking pre-selector are not required for this measurement. The analyzer is set to zero span, tuned to the center frequency of the UUT operating *Channel*, with a peak detector function, and a 32 minute sweep time. If any UUT transmissions occur within the observation time, they are detected and recorded.

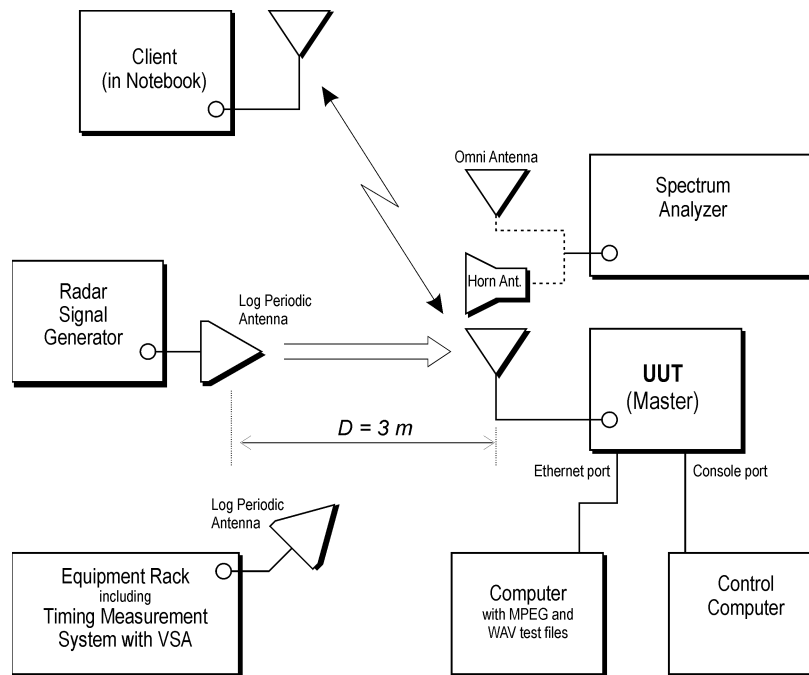

Figure 13: Example DFS Timing Monitoring Diagram for Method #1

### 7.6.2 Method #2

The test setup of the Method #2 DFS monitoring subsystem is shown in **Figure 14**. This provides coarser timing measurements than Method #1 and provides an upper bound measurement of the aggregate duration of the *Channel Closing Transmission Time*.

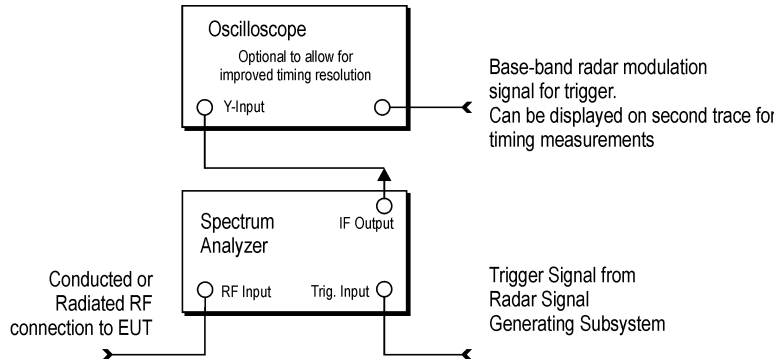

Figure 14: Example DFS Timing Monitoring Diagram for Method #2

With the spectrum analyzer set to zero span tuned to the center frequency of the UUT operating channel at the radar simulated frequency, peak detection, and max hold, the dwell time per bin is given by:

$$\text{Dwell} = S / B$$

where **Dwell** is the dwell time per spectrum analyzer sampling bin, **S** is the sweep time and **B** is the number of spectrum analyzer sampling bins.

An upper bound of the aggregate duration of the *Channel Closing Transmission Time* is calculated by:

$$C = N * \text{Dwell}$$

where **C** is the Closing Time, **N** is the number of spectrum analyzer sampling bins showing a U-NII transmission and **Dwell** is the dwell time per bin.

## 7.7 Channel Loading

System testing will be performed with channel-loading using means appropriate to the data types that are used by the unlicensed device. The following requirements apply:

- a) The data file must be of a type that is typical for the device (i.e., MPEG-2, MPEG-4, WAV, MP3, MP4, AVI, etc.) and must generally be transmitting in a streaming mode.
- b) Software to ping the client is permitted to simulate data transfer but must have random ping intervals.
- c) Timing plots are required with calculations demonstrating a minimum channel loading of approximately 17% or greater.
- d) Unicast or Multicast protocols are preferable but other protocols may be used. The appropriate protocol used must be described in the test procedures.

### 7.7.1 IP Based Systems

The channel loading data file will be transferred from the *Master Device* to the *Client Device* for all test configurations.

### 7.7.2 Frame Based Systems

The channel loading test file will be transferred from the *Master Device* to the *Client Device* for all test configurations. For frame based systems with a fixed talk/listen ratio, the ratio systems will be set to the

worst case (maximum) that is user configurable during this test as specified by the manufacturer. For frame based systems that dynamically allocate the talk/listen ratio, the channel loading test file will be transferred from the *Master Device* to the *Client Device* for all test configurations.

### 7.7.3 Other Systems

Systems that do not employ IP or frame based architectures, or that represent a combination of the two, must submit a description of their system architecture to the FCC for evaluation through the FCC inquiry system.<sup>7</sup>

## 7.8 DFS CONFORMANCE TEST PROCEDURES

The tests in this section are run sequentially and the UUT must pass all tests successfully. If the UUT fails any one of the tests it will count as a failure of compliance. To show compliance, all tests must be performed with waveforms randomly generated as specified with test results meeting the required percentage of successful detection criteria. All test results must be reported to the FCC. One frequency will be chosen from the operating *Channels* of the UUT within the 5250-5350 MHz or 5470-5725 MHz bands.

### 7.8.1 U-NII Detection Bandwidth

Set up the generating equipment as shown in **Figure 8**, or equivalent. Set up the DFS timing monitoring equipment as shown in **Figure 13** or **Figure 14**. Set up the overall system for either radiated or conducted coupling to the UUT.

Adjust the equipment to produce a single *Burst* of any one of the Short Pulse Radar Types 0 – 4 in **Table 5** at the center frequency of the UUT *Operating Channel* at the specified *DFS Detection Threshold* level found in **Table 3**.

Set the UUT up as a standalone device (no associated Client or Master, as appropriate) and no traffic. Frame based systems will be set to a talk/listen ratio reflecting the worst case (maximum) that is user configurable during this test.

Generate a single radar *Burst*, and note the response of the UUT. Repeat for a minimum of 10 trials. The UUT must detect the *Radar Waveform* within the DFS band using the specified *U-NII Detection Bandwidth* criterion shown in **Table 4**. In cases where the channel bandwidth may exceed past the DFS band edge on specific channels (i.e., 802.11ac or wideband frame based systems) select a channel that has the entire emission bandwidth within the DFS band. If this is not possible, test the detection BW to the DFS band edge.

Starting at the center frequency of the UUT operating *Channel*, increase the radar frequency in 5 MHz steps, repeating the above test sequence, until the detection rate falls below the *U-NII Detection Bandwidth* criterion specified in **Table 4**. Repeat this measurement in 1MHz steps at frequencies 5 MHz below where the detection rate begins to fall. Record the highest frequency (denote as  $F_H$ ) at which detection is greater than or equal to the *U-NII Detection Bandwidth* criterion. Recording the detection rate at frequencies above  $F_H$  is not required to demonstrate compliance.

Starting at the center frequency of the UUT operating *Channel*, decrease the radar frequency in 5 MHz steps, repeating the above test sequence, until the detection rate falls below the *U-NII Detection Bandwidth* criterion specified in **Table 4**. Repeat this measurement in 1MHz steps at frequencies 5 MHz

---

<sup>7</sup> Submit inquiries at <https://www.fcc.gov/labhelp>.

above where the detection rate begins to fall. Record the lowest frequency (denote as  $F_L$ ) at which detection is greater than or equal to the *U-NII Detection Bandwidth* criterion. Recording the detection rate at frequencies below  $F_L$  is not required to demonstrate compliance.

The *U-NII Detection Bandwidth* is calculated as follows:

$$U\text{-NII Detection Bandwidth} = F_H - F_L$$

The *U-NII Detection Bandwidth* must meet the *U-NII Detection Bandwidth* criterion specified in **Table 4**. Otherwise, the UUT does not comply with DFS requirements. This is essential to ensure that the UUT is capable of detecting *Radar Waveforms* across the same frequency spectrum that contains the significant energy from the system. In the case that the *U-NII Detection Bandwidth* is greater than or equal to the 99 percent power bandwidth for the measured  $F_H$  and  $F_L$ , the test can be truncated and the *U-NII Detection Bandwidth* can be reported as the measured  $F_H$  and  $F_L$ .

### 7.8.2 Performance Requirements Check

The following tests must be performed for U-NII device certification: Initial *Channel Startup Check* with a radar *Burst* at start of *Channel Availability Check* and with a radar *Burst* at end of *Channel Availability Check*; *In-Service Monitoring*; and the 30 minute *Non-Occupancy Period*.

#### 7.8.2.1 Initial Channel Availability Check Time

The Initial *Channel Availability Check Time* tests that the UUT does not emit beacon, control, or data signals on the test *Channel* until the power-up sequence has been completed and the U-NII device checks for *Radar Waveforms* for one minute on the test *Channel*. This test does not use any *Radar Waveforms* and only needs to be performed one time.

- a) The U-NII devices will be powered on and be instructed to operate on the appropriate U-NII *Channel* that must incorporate DFS functions. At the same time the UUT is powered on, the spectrum analyzer will be set to zero span mode with a 3 MHz RBW and 3 MHz VBW on the *Channel* occupied by the radar ( $Ch_r$ ) with a 2.5 minute sweep time. The spectrum analyzer's sweep will be started at the same time power is applied to the U-NII device.
- b) The UUT should not transmit any beacon or data transmissions until at least 1 minute after the completion of the power-on cycle.

This measurement can be used to determine the length of the power-on cycle if it is not supplied by the manufacturer. If the spectrum analyzer sweep is started at the same time the UUT is powered on and the UUT does not begin transmissions until it has completed the cycle, the power-on time can be determined by comparing the two times.

#### 7.8.2.2 Radar Burst at the Beginning of the Channel Availability Check Time

The steps below define the procedure to verify successful radar detection on the test *Channel* during a period equal to the *Channel Availability Check Time* and avoidance of operation on that *Channel* when a radar *Burst* with a level equal to the *DFS Detection Threshold* + 1 dB occurs at the beginning of the *Channel Availability Check Time*. This is illustrated in **Figure 15**.

- a) The *Radar Waveform* generator and UUT are connected using the applicable test setup described in the sections on configuration for Conducted Tests (7.2) or Radiated Tests (7.3) and the power of the UUT is switched off.

- b) The UUT is powered on at  $T_0$ .  $T_1$  denotes the instant when the UUT has completed its power-up sequence ( $T_{power\_up}$ ). The *Channel Availability Check Time* commences on  $Ch_r$  at instant  $T_1$  and will end no sooner than  $T_1 + T_{ch\_avail\_check}$ .
- c) A single *Burst* of one of the Short Pulse Radar Types 0-4 will commence within a 6 second window starting at  $T_1$ . An additional 1 dB is added to the radar test signal to ensure it is at or above the *DFS Detection Threshold*, accounting for equipment variations/errors.
- d) Visual indication or measured results on the UUT of successful detection of the radar *Burst* will be recorded and reported. Observation of  $Ch_r$  for UUT emissions will continue for 2.5 minutes after the radar *Burst* has been generated.
- e) Verify that during the 2.5 minute measurement window no UUT transmissions occurred on  $Ch_r$ . The *Channel Availability Check* results will be recorded.

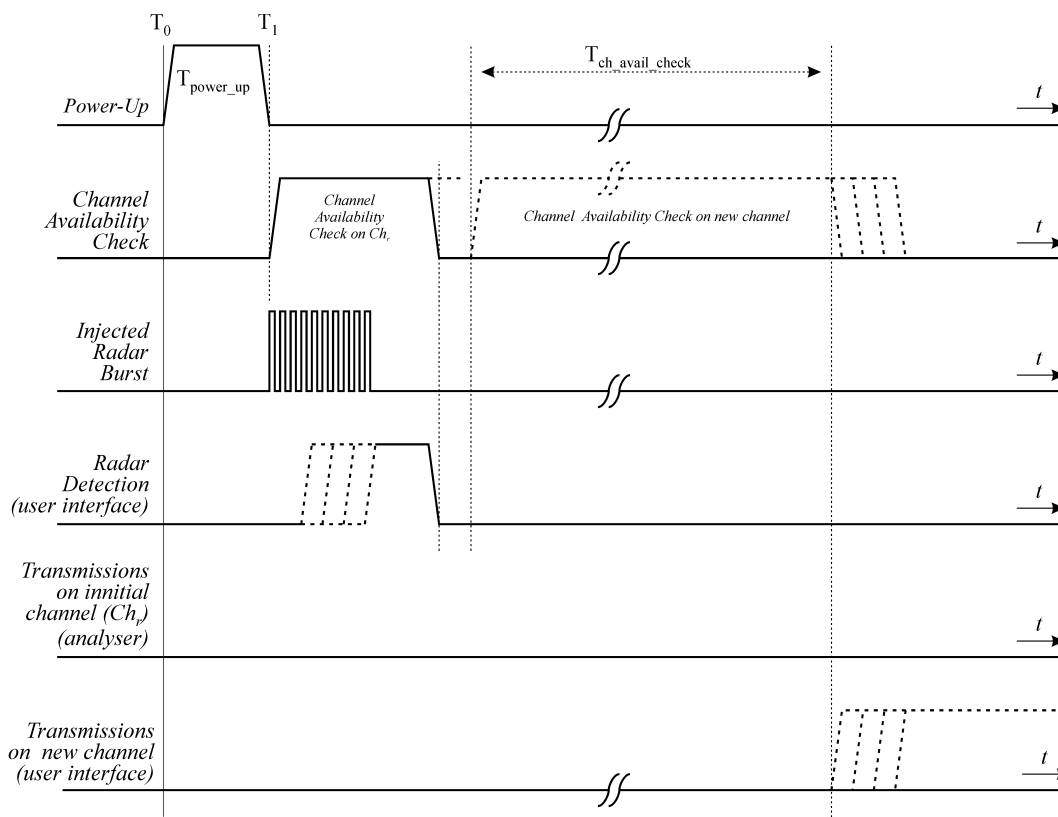

Figure 15: Example of timing for radar testing at the beginning of the Channel Availability Check Time

### 7.8.2.3 Radar Burst at the End of the Channel Availability Check Time

The steps below define the procedure to verify successful radar detection on the test *Channel* during a period equal to the *Channel Availability Check Time* and avoidance of operation on that *Channel* when a radar *Burst* with a level equal to the *DFS Detection Threshold* + 1dB occurs at the end of the *Channel Availability Check Time*. This is illustrated in **Figure 16**.



- a) The *Radar Waveform* generator and UUT are connected using the applicable test setup described in the sections for Conducted Tests (7.2) or Radiated Tests (7.3) and the power of the UUT is switched off.
- b) The UUT is powered on at  $T_0$ .  $T_1$  denotes the instant when the UUT has completed its power-up sequence ( $T_{power\_up}$ ). The *Channel Availability Check Time* commences on  $Ch_r$  at instant  $T_1$  and will end no sooner than  $T_1 + T_{ch\_avail\_check}$ .
- c) A single *Burst* of one of the Short Pulse Radar Types 0-4 will commence within a 6 second window starting at  $T_1 + 54$  seconds. An additional 1 dB is added to the radar test signal to ensure it is at or above the *DFS Detection Threshold*, accounting for equipment variations/errors.
- d) Visual indication or measured results on the UUT of successful detection of the radar *Burst* will be recorded and reported. Observation of  $Ch_r$  for UUT emissions will continue for 2.5 minutes after the radar *Burst* has been generated.
- e) Verify that during the 2.5 minute measurement window no UUT transmissions occurred on  $Ch_r$ . The *Channel Availability Check* results will be recorded.

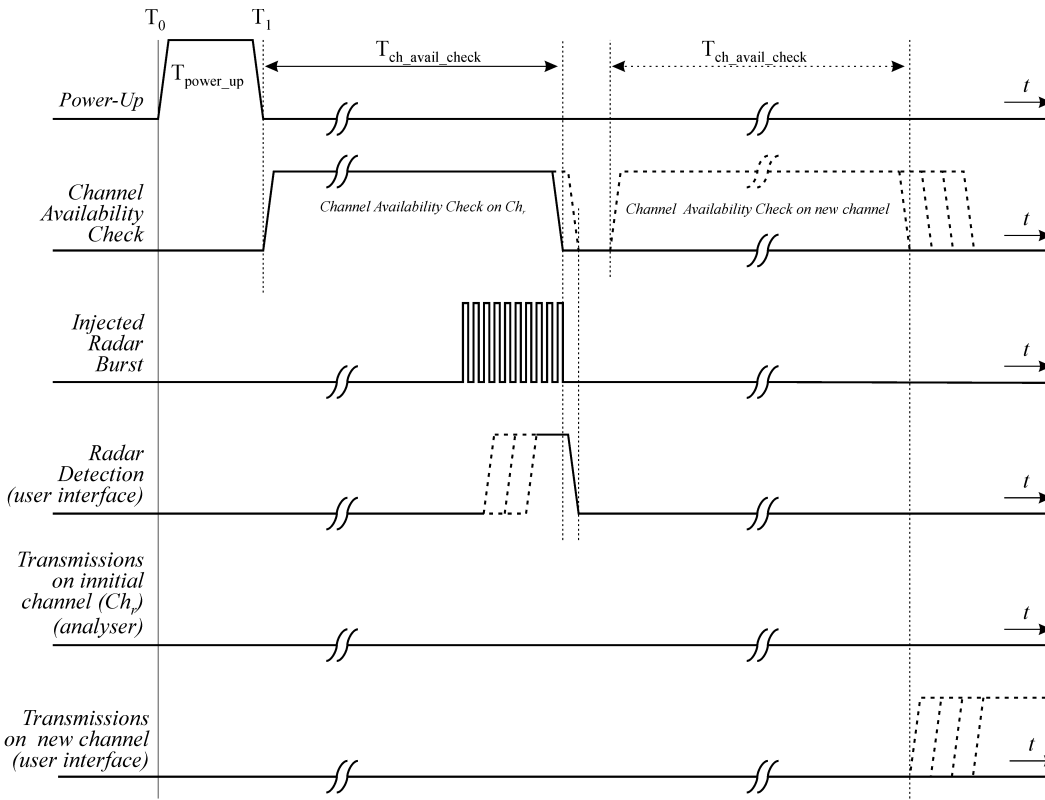

Figure 16: Example of timing for radar testing towards the end of the Channel Availability Check Time

### 7.8.3 In-Service Monitoring for Channel Move Time, Channel Closing Transmission Time and Non-Occupancy Period

These tests define how the following DFS parameters are verified during *In-Service Monitoring*;

- *Channel Closing Transmission Time*

- *Channel Move Time*
- *Non-Occupancy Period*

The steps below define the procedure to determine the above mentioned parameters when a radar *Burst* with a level equal to the *DFS Detection Threshold* + 1dB is generated on the *Operating Channel* of the U-NII device (*In- Service Monitoring*).

- a) One frequency will be chosen from the *Operating Channels* of the UUT within the 5250-5350 MHz or 5470-5725 MHz bands. For 802.11 devices, the test frequency must contain control signals. This can be verified by disabling channel loading and monitoring the spectrum analyzer. If no control signals are detected, another frequency must be selected within the emission bandwidth where control signals are detected.
- b) In case the UUT is a U-NII device operating as a *Client Device* (with or without DFS), a U-NII device operating as a *Master Device* will be used to allow the UUT (Client device) to *Associate* with the *Master Device*. In case the UUT is a *Master Device*, a U-NII device operating as a *Client Device* will be used and it is assumed that the Client will *Associate* with the UUT (Master). In both cases for conducted tests, the *Radar Waveform* generator will be connected to the *Master Device*. For radiated tests, the emissions of the *Radar Waveform* generator will be directed towards the *Master Device*. If the *Master Device* has antenna gain, the main beam of the antenna will be directed toward the radar emitter. Vertical polarization is used for testing.
- c) Stream the channel loading test file from the *Master Device* to the *Client Device* on the test *Channel* for the entire period of the test.
- d) At time  $T_0$  the *Radar Waveform* generator sends a *Burst* of pulses for one of the Short Pulse Radar Types 1-4 in **Table 5** at levels defined in **Table 3**, on the *Operating Channel*. An additional 1 dB is added to the radar test signal to ensure it is at or above the *DFS Detection Threshold*, accounting for equipment variations/errors.
- e) Observe the transmissions of the UUT at the end of the radar *Burst* on the *Operating Channel* for duration greater than 10 seconds. Measure and record the transmissions from the UUT during the observation time (*Channel Move Time*). Measure and record the *Channel Move Time* and *Channel Closing Transmission Time* if radar detection occurs. **Figure 17** illustrates *Channel Closing Transmission Time*.
- f) When operating as a *Master Device*, monitor the UUT for more than 30 minutes following instant  $T_2$  to verify that the UUT does not resume any transmissions on this *Channel*. Perform this test once and record the measurement result.
- g) In case the UUT is a U-NII device operating as a *Client Device* with *In-Service Monitoring*, perform steps a) to f).

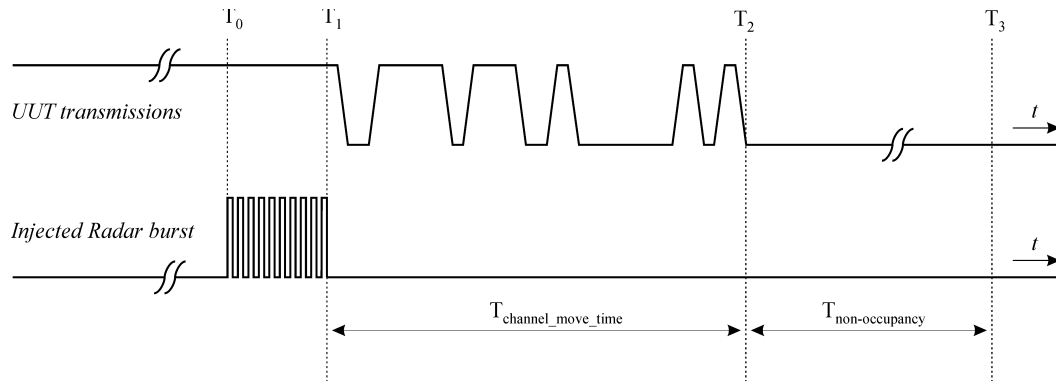

Figure 17: Example of Channel Closing Transmission Time & Channel Closing Time

#### 7.8.4 Statistical Performance Check

The steps below define the procedure to determine the minimum percentage of successful detection requirements found in **Tables 5-7** when a radar burst with a level equal to the *DFS Detection Threshold* + 1dB is generated on the *Operating Channel* of the U-NII device (*In-Service Monitoring*).

- a) One frequency will be chosen from the *Operating Channels* of the UUT within the 5250-5350 MHz or 5470-5725 MHz bands.
- b) In case the UUT is a U-NII device operating as a *Client Device* (with or without Radar Detection), a U-NII device operating as a *Master Device* will be used to allow the UUT (*Client device*) to *Associate* with the *Master Device*. In case the UUT is a *Master Device*, a U-NII device operating as a *Client Device* will be used and it is assumed that the *Client* will *Associate* with the UUT (*Master*). In both cases for conducted tests, the *Radar Waveform* generator will be connected to the *Master Device*. For radiated tests, the emissions of the *Radar Waveform* generator will be directed towards the *Master Device*. If the *Master Device* has antenna gain, the main beam of the antenna will be directed toward the radar emitter. Vertical polarization is used for testing.
- c) Stream the channel loading test file from the *Master Device* to the *Client Device* on the test *Channel* for the entire period of the test.
- d) At time  $T_0$  the *Radar Waveform* generator sends the individual waveform for each of the Radar Types 1-6 in **Tables 5-7**, at levels defined in **Table 3**, on the *Operating Channel*. An additional 1 dB is added to the radar test signal to ensure it is at or above the *DFS Detection Threshold*, accounting for equipment variations/errors.
- e) Observe the transmissions of the UUT at the end of the Burst on the *Operating Channel* for duration greater than 10 seconds for Short Pulse Radar Types 1-4 and 6 to ensure detection occurs.

- f) Observe the transmissions of the UUT at the end of the Burst on the *Operating Channel* for duration greater than 22 seconds for Long Pulse Radar Type 5 to ensure detection occurs.
- g) In case the UUT is a U-NII device operating as a *Client Device* with *In-Service Monitoring*, perform steps a) to f).

#### 7.8.4.1 Short Pulse Radar Test

Once the performance requirements check is complete, statistical data will be gathered, to determine the ability of the device to detect the radar test waveforms (Short Pulse Radar Types 1-4) found in **Table 5**. The device can utilize a test mode to demonstrate when detection occurs to prevent the need to reset the device between trials. The percentage of successful detection is calculated by:

$$\frac{\text{TotalWaveformDetections}}{\text{TotalWaveformTrials}} \times 100 = \text{Percentage of Successful Detection Radar Waveform } N = P_d N$$

In addition an aggregate minimum percentage of successful detection across all Short Pulse Radar Types 1-4 is required and is calculated as follows:

$$\frac{P_d 1 + P_d 2 + P_d 3 + P_d 4}{4}$$

The minimum number of trails, minimum percentage of successful detection and the aggregate minimum percentage of successful detection are found in **Table 5**.

#### 7.8.4.2 Long Pulse Radar Test

Statistical data will be gathered to determine the ability of the device to detect the Long Pulse Radar Type 5 found in **Table 6**. The device can utilize a test mode to demonstrate when detection occurs to prevent the need to reset the device between trials. The percentage of successful detection is calculated by:

$$\frac{\text{TotalWaveformDetections}}{\text{TotalWaveformTrials}} \times 100$$

#### 7.8.4.3 Frequency Hopping Radar Test

Statistical data will be gathered to determine the ability of the device to detect the Frequency Hopping radar test signal (radar type 6) found in **Table 7**. The device can utilize a test mode to demonstrate when detection occurs to prevent the need to reset the device between trial runs. The probability of successful detection is calculated by:

$$\frac{\text{TotalWaveformDetections}}{\text{TotalWaveformTrials}} \times 100$$

## 8. DFS TEST REPORT GUIDELINES

The following items will be included in test reports for DFS testing of U-NII devices as indicated in the sections below. This section covers the minimum requirements that will be submitted on the DFS test results.

### 8.1 Complete description of the U-NII device

1. The operating frequency range(s) of the equipment.

2. The operating modes (Master and/or Client) of the U-NII device. Bridge modes and MESH modes, as applicable, must be included in the description.
3. For Client devices, indicate whether or not it has radar detection capability and indicate the FCC identifier for the Master U-NII Device that is used with it for DFS testing.
4. List the highest and the lowest possible power level (equivalent isotropic radiated power (EIRP)) of the equipment.
5. List all antenna assemblies and their corresponding gains.
  - a. If radiated tests are to be performed, the U-NII Device should be tested with the lowest gain antenna assembly (regardless of antenna type). The report should indicate which antenna assembly was used for the tests. For devices with adjustable output power, list the output power range and the maximum EIRP for each antenna assembly.
  - b. If conducted tests are to be performed, indicate which antenna port/connection was used for the tests and the antenna assembly gain that was used to set the *DFS Detection Threshold* level during calibration of the test setup.
    - i. Indicate the calibrated conducted *DFS Detection Threshold* level.
    - ii. For devices with adjustable output power, list the output power range and the maximum EIRP for each antenna assembly.
    - iii. Indicate the antenna connector impedance. Ensure that the measurement instruments match (usually 50 Ohms) or use a minimum loss pad and take into account the conversion loss.
  - c. Antenna gain measurement verification for tested antenna.
    - i. Describe procedure
    - ii. Describe the antenna configuration and how it is mounted
    - iii. If an antenna cable is supplied with the device, cable loss needs to be taken into account. Indicate the maximum cable length and either measure the gain with this cable or adjust the measured gain accordingly. State the cable loss.
6. Test sequences or messages that should be used for communication between Master and *Client Devices*, which are used for loading the *Channel*.
  - a. Stream the test file from the *Master Device* to the *Client Device* for IP based systems or frame based systems which dynamically allocate the talk/listen ratio.
  - b. For frame based systems with fixed talk/listen ratio, set the ratio to the worst case (maximum) that is user configurable during this test as specified by the manufacturer and stream the test file from the *Master* to the *Client*.
  - c. For other system architectures, supply appropriate *Channel* loading methodology.
7. Transmit Power Control description  
Provide a description.
8. System architectures, data rates, U-NII *Channel* bandwidths.
  - a. Indicate the type(s) of system architecture (e.g. IP based or Frame based) that the U-NII device employs. Each type of unique architecture must be tested.
9. The time required for the *Master Device* and/or *Client Device* to complete its power-on cycle.
10. Manufacturer statement confirming that information regarding the parameters of the detected *Radar Waveforms* is not available to the end user.
11. The manufacturer is permitted to select the first channel either manually or randomly. The manufacturer may also block DFS channels from use.

## 8.2 Complete description of the Radar Waveform calibration

1. Description of calibration setup

- a. Block diagram of equipment setup, clearly identifying if a radiated or conducted method was used.
2. Description of calibration procedure
  - a. Verify *DFS Detection Threshold* levels
    - i. Indicate *DFS Detection Threshold* levels used.
    - ii. Consider output power range and antenna gain.
  - b. For the Short Pulse Radar Types, spectrum analyzer plots of the burst of pulses on the *Channel* frequency should be provided.
  - c. For the Long Pulse Radar Type, spectrum analyzer plot of a single burst (1-3 pulses) on the *Channel* frequency should be provided.
  - d. Describe method used to generate frequency hopping signal.
  - e. The *U-NII Detection Bandwidth*
  - f. For the Frequency Hopping waveform, a spectrum analyzer plot showing 9 pulses on one frequency within the *U-NII Detection Bandwidth* should be provided.
  - g. Verify use of vertical polarization for testing when using a radiated test method.
3. When testing a *Client Device* with radar detection capability, verify that the *Client Device* is responding independently based on the *Client Device's* self-detection rather than responding to the *Master Device*. If required, provide a description of the method used to isolate the client from the transmissions from the *Master Device* to ensure *Client Device* self detection of the *Radar Waveform*.

### 8.3 Complete description of test procedure

1. Description of deviations to the procedures or equipment described in this document.
2. Description of DFS test procedure and test setup used to monitor the U-NII device and *Radar Waveform* transmissions. Provide a block diagram of the signal monitoring equipment setup.
  - a. List of equipment
  - b. Test setup photos
3. Description of DFS test procedure and test setup used to generate the *Radar Waveforms*.
  - a. Block diagram of equipment setup
  - b. List of equipment
  - c. Test setup photos
  - d. For each of the waveforms that were used for each signal type, supply the characteristics (pulse width, pulse repetition interval, number of pulses per burst, modulation).
  - e. For selecting the waveform parameters from within the bounds of the signal type, describe how they were selected (i.e., manually or randomly).
  - f. Channel loading description including data type, timing plots, percentage loading calculation, and protocol.
4. The DFS tests are to be performed on U-NII *Channel(s)* at the smallest U-NII *Channel* bandwidth (worst case).
  - i. List each *Channel* frequency that was used for the tests.
  - ii. Data Sheet showing the *U-NII Detection Bandwidth* for the *Channel(s)* used during the test.
  - iii. Plot of RF measurement system showing its nominal noise floor in the same bandwidth which is used to perform the *Channel Availability Check*, initial radar bursts, *In-Service Monitoring*, and 30 minute *Non-Occupancy Period* tests.
5. Timing plot(s) showing compliance with the *Channel Availability Check Time* requirement of 60 seconds at start up.



- a. The plot should show the Initial  $T_{\text{power-up}}$  time.
  - b. The plot should include the Initial  $T_{\text{power-up}}$  period in addition to 60 second period.
6. Timing plot(s) showing compliance with the Initial DFS radar detection requirements during the 60 second initial *Channel Availability Check* at start up.
  - a. Plot for DFS radar detection for *Radar Waveforms* applied 6 seconds after the Initial  $T_{\text{power-up}}$  time period. The minimum length of the plot should be 1.5 minutes after the  $T_{\text{power-up}}$  time period. The plot should show the radar burst at the appropriate time. This test is only required once and any one of the Short Pulse radar Types 0 – 4 can be used for the test.
  - b. Plot for DFS radar detection for *Radar Waveforms* applied 6 seconds before end of the 60 second *Channel Availability Check* Time. The minimum length of the plot should be 1.5 minutes  $T_{\text{power-up}}$  time period. The plot should show the radar burst at the appropriate time. This test is only required once and any one of the Short Pulse Radar Types 0 – 4 can be used for the test.
  - c. The minimum time resolution of the plots should be sufficient to show the *Radar Waveform* bursts (overall, not individual pulses within the burst).
7. Verification that when the device is “off” that the RF energy emitted is below the FCC rules for unintentional radiators:

For the plots of U-NII RF activity versus time, the device is considered to be “off” or not transmitting when intentional U-NII signals (beacons, data packets or transmissions, or control signals) are below the FCC rules for unintentional radiation due to device leakage, oscillator noise, clocks, and other unintentional RF generators.
8. Spectrum Analyzer, VSA, or some other data gathering Instrument plots showing compliance with the *Channel Move Time* requirements during in the *In-Service Monitoring* testing for the Short and Long Pulse Radar Types. The plots need to show U-NII device transmissions on the *Channel* in the form of RF activity on the vertical axis versus time on the horizontal axis. Only one 10 second plot needs to be reported for the Short Pulse Radar Types 1-4 and one for the Long Pulse Radar Type in a 22 second plot. The plot for the Short Pulse Radar Types should start at the end of the radar burst. The Long Pulse Radar Type plot only needs to show the device ceased transmissions within the 10 second window after detection has occurred. The plot for the Long Pulse Radar Type should start at the beginning of the 12 second waveform. However, the *Channel Move Time* will be calculated based on the plot of the Short Pulse Radar type.

The plots need to show U-NII device transmissions on the *Channel* in the form of RF activity on the vertical axis versus time on the horizontal axis. Sufficient resolution should be used.

Only one 10 second plot needs to be reported for the Short Pulse Radar Types 1-4 and one for the Long Pulse Radar Type test in a 22 second plot. The plot for the Short Pulse Radar Types should start at the end of the radar burst. The *Channel Move Time* will be calculated based on the plot of the Short Pulse Radar Type.

The Long Pulse Radar Type plot only needs to show the device ceased transmissions within the 10 second window after detection has occurred. The plot for the Long Pulse Radar Type should start at the beginning of the 12 second waveform.

  - a. The plots and/or data must show the U-NII Device’s compliance with the 200 milliseconds limit on data transmission and compliance with the 60 millisecond aggregate limit found in **Table 4**.
  - b. Indicate the total number of times the test was performed.

- c. Indicate a detect/not detect for each waveform within a signal type and the number of failures and the number of successful radar detection times within the time limit. Sample data sheets are shown in **Tables 8-10**.
  - d. Verify compliance with the minimum percentage of successful detection requirements found in **Tables 5-7**.
9. Spectrum Analyzer plot(s) showing compliance with the 30 minute *Non-Occupancy Period* requirement.  
 Only one plot is required. This is a separate test that is performed in addition to the other *In-Service Monitoring* tests. However, any type of *Radar Waveform* can be used for this test.

**Table 8: Sample Detection Data Sheet for Radar Types 1, 5, and 6  
 (Use a Separate Data Sheet for Each Radar Type)**

Radar Type	Trial #	Detection	Trial #	Detection
		Yes / No		Yes / No
<b>1, 5 or 6</b>	<b>1</b>		<b>16</b>	
	<b>2</b>		<b>17</b>	
	<b>3</b>		<b>18</b>	
	<b>4</b>		<b>19</b>	
	<b>5</b>		<b>20</b>	
	<b>6</b>		<b>21</b>	
	<b>7</b>		<b>22</b>	
	<b>8</b>		<b>23</b>	
	<b>9</b>		<b>24</b>	
	<b>10</b>		<b>25</b>	
	<b>11</b>		<b>26</b>	
	<b>12</b>		<b>27</b>	
	<b>13</b>		<b>28</b>	
	<b>14</b>		<b>29</b>	
	<b>15</b>		<b>30</b>	



**Table 9: Sample Data Sheet for Radar Types 2, 3, or 4  
(Use a Separate Data Sheet for Each Radar Type)**

Radar Type	Trial #	Number Pulses per Burst	Pulse Width (μs)	PRI (μs)	Detection
					Yes / No
2, 3, or 4	1				
	2				
	3				
	4				
	5				
	6				
	7				
	8				
	9				
	10				
	11				
	12				
	13				
	14				
	15				
	16				
	17				
	18				
	19				
	20				
	21				
	22				
	23				
	24				
	25				
	26				
	27				
	28				
	29				
	30				

**Table 10: Sample Parameter Data Sheet for Radar Type 5**  
 (Use a separate data sheet for each trial)

<b>RADAR TYPE 5</b>						
<b>Trial Number:</b>						
<b>Number of Bursts in Trial:</b>						
<b>Burst</b>	<b>Number of Pulses</b>	<b>Pulse Width (μsec)</b>	<b>Chirp Width (MHz)</b>	<b>Pulse 1-to-2 Spacing (μsec)</b>	<b>Pulse 2-to-3 Spacing (μsec)</b>	<b>Starting Location Within Interval (μsec)</b>
1						
2						
3						
4						
5						
6						
7						
8						
9						
10						
11						
12						
13						
14						
15						
16						
17						
18						
19						
20						

905462 D06 – 802.11 Channel Plans effective 2014 v01

**OPERATION IN U-NII BANDS – 802.11 CHANNEL PLAN §15.407 (Part 15E), 1st R&O, Release 4/1/2014**

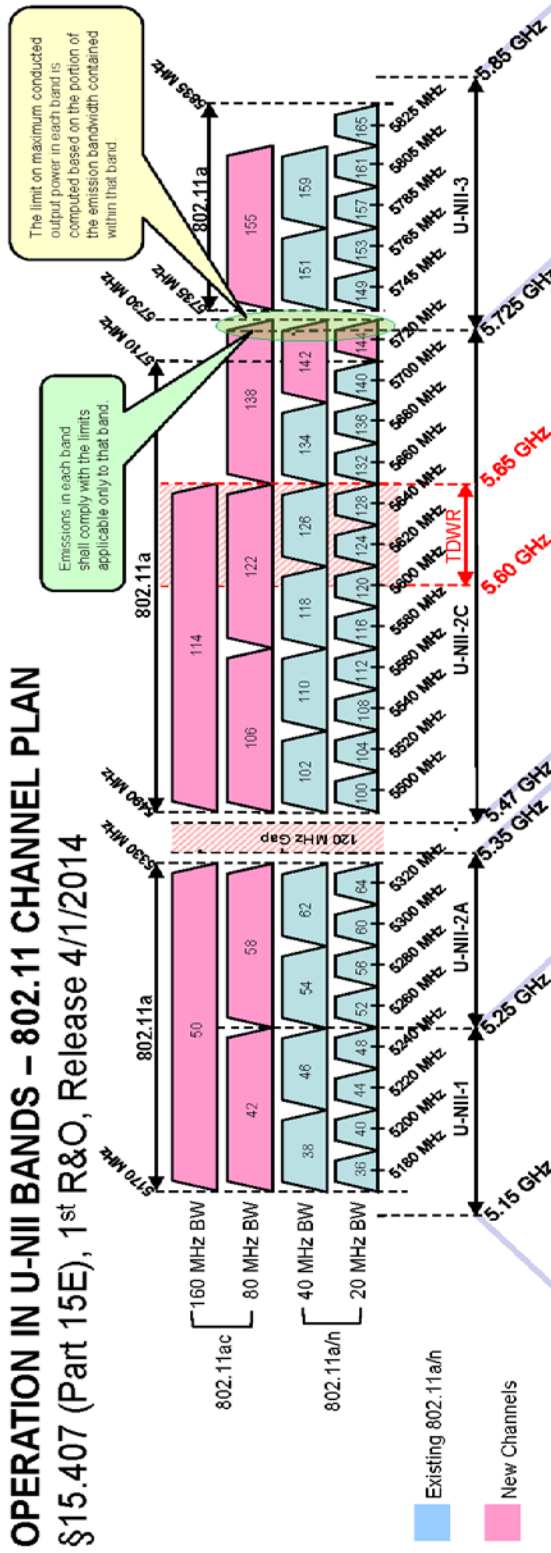

Frequency Range (MHz)	Condition of Operation	5150-5250	5250-5350	5470-5725	5725-5850
Max Conducted TX Power	Indoor/Outdoor, Master/Client, mobile/portable, and fixed Device, unless otherwise noted	30 dBm (1 W) for master device 24 dBm (250 mW) for mobile/portable client device	24dBm (250 mW) or 11 dBm + 10 log B, whichever is lower (B= 26-dB emission BW)		30 dBm (1 W)
Max_ERP		4 W (36 dBm) with 6 dBi antenna 200 W (53 dBm) for fixed P-t-P application with 23 dBi antenna Additional rule for outdoor operation: Max_ERIP < 125 mW (21 dBm) at any elevation angle > 30° from horizon		1 W (30 dBm) with 6 dBi antenna	4 W (36 dBm) with 6 dBi antenna No EIRP limit for fixed P-t-P application (i.e. no antenna gain limit)
TX Power Reduction (dBm-by-dBi) required when antenna exceeds...		> 23 dBi for fixed P-t-P application		> 6 dBi	> 6dBi Not required for fixed P-t-P application with any antenna gain
Out of Band e.i.r.p. Emission		< -27 dBm/MHz outside 5150-5350 MHz		< -27 dBm/MHz outside 5470-5725 MHz	< -17 dBm/MHz within 5715-5725 MHz and 5850-5860 MHz < -27 dBm/MHz outside 5715-5860 MHz
Max Conducted Power Spectral Density (PSD)		17 dBm/MHz for master device 11 dBm/MHz for mobile/portable client device		11 dBm/MHz	30 dBm/500kHz
Dynamic Frequency Selection (DFS) required?		NO	YES, for master device with Detection Threshold of -64 dBm for 200 mW (23 dBm) ≤ Operating_ERIP ≤ 1W (30 dBm); -62dBm for Operating_ERIP < 200 mW (23 dBm) and PSD must be < 10 dBm/MHz. Device must sense for radar signals at 100% of its emission BW		NO
Transmit Power Control (TPC) required?		NO	YES, if Max_ERIP ≥ 500 mW (27 dBm) and able to lower EIRP below 24dBm		NO
Minimum BW requirement		N/A			6-dB BW ≥ 500 kHz